

Assembled size / Maße aufgebaut :

Height / Höhe : 2000 mm.

Width / Breite : 1010 mm.

Depth / Tiefe : 404 mm.

This unit can be assembled by two persons.

Aufbau mit zwei Personen.

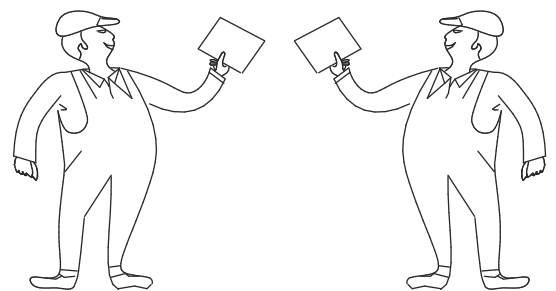







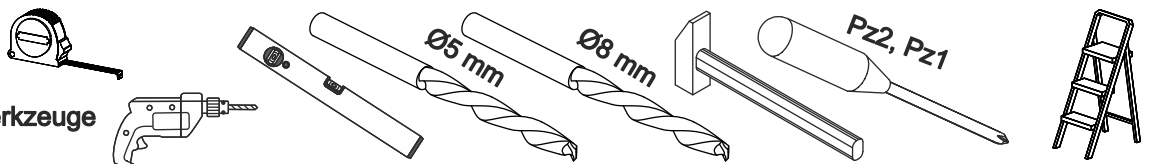

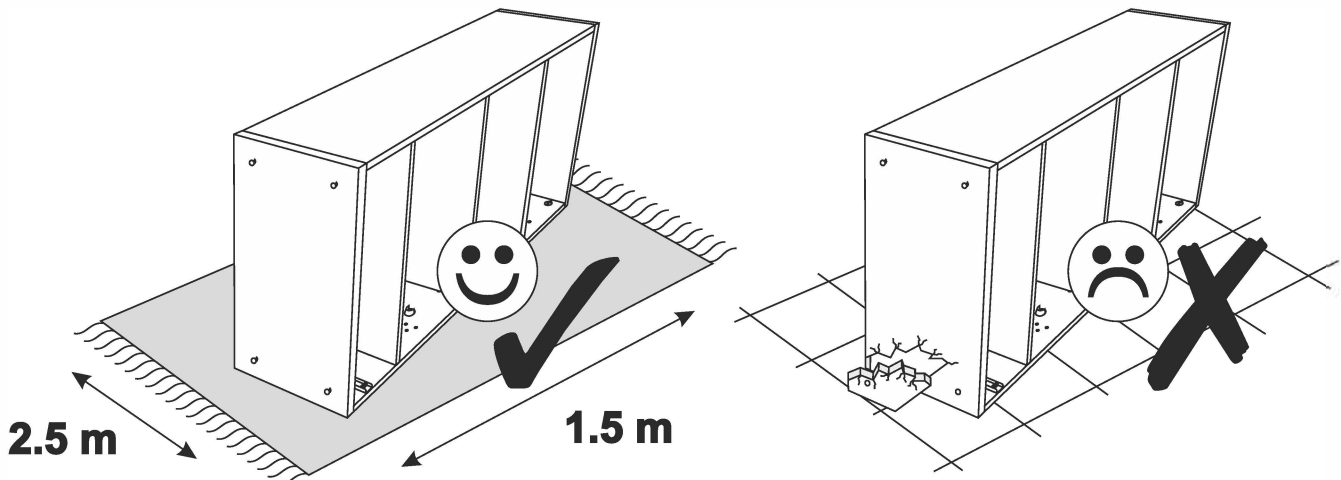
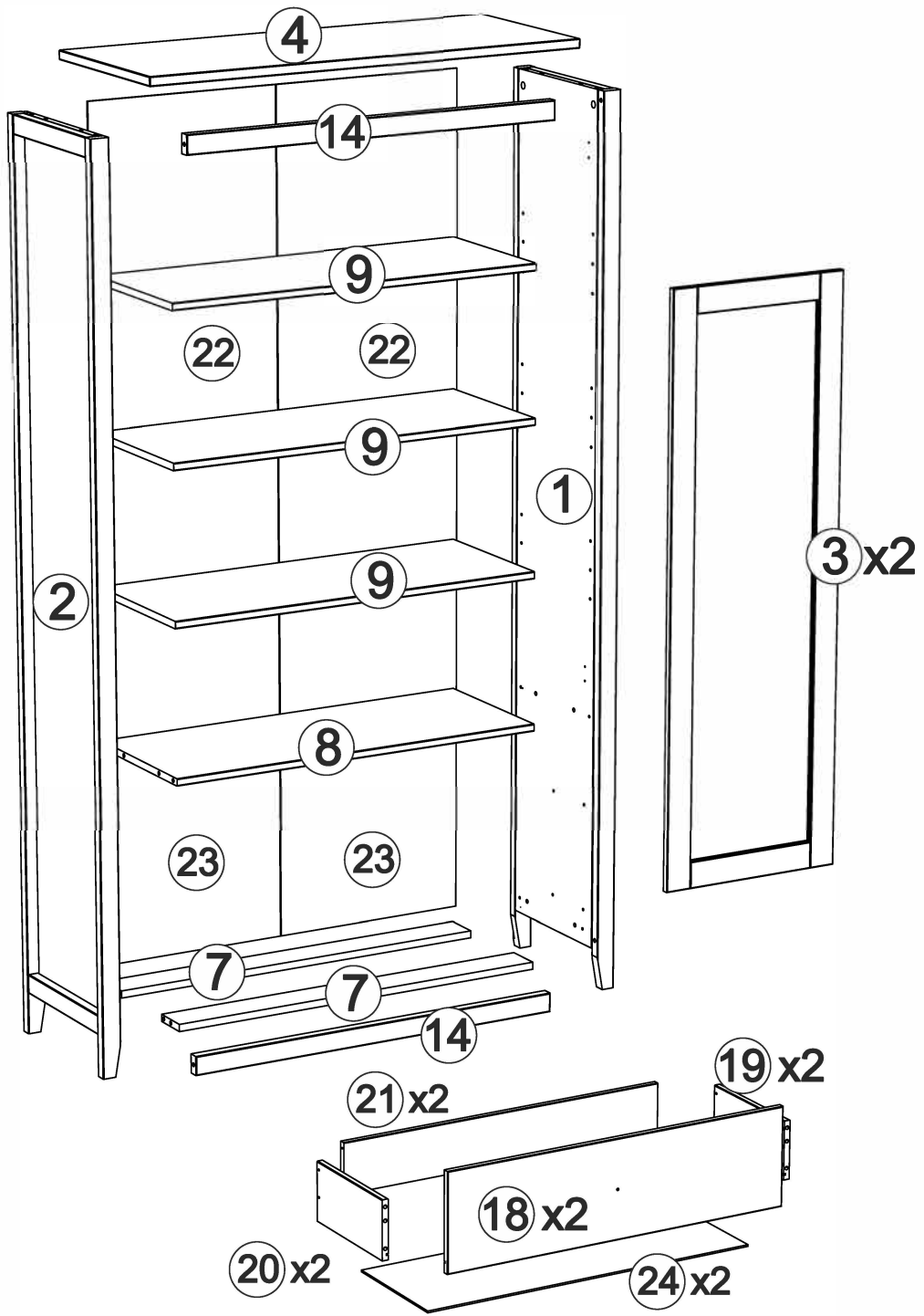

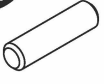
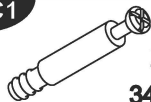



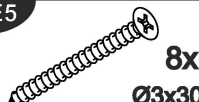

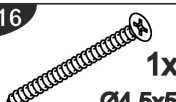

Beachten Sie bitte:
Massiv-Holz ist ein organisches Material und passt sich den jeweiligen Umweltbedingungen an.
Leichter Verzug, Haarrisse und Oberflächendetails sind daher kein Reklamationsgrund,
sondern ein Qualitätsmerkmal des Materials.

The necessary tools (not included)

Die dazu benötigten Werkzeuge (ausschliesslich)



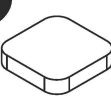

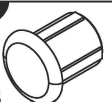
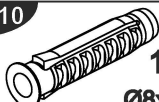
B1  20x Ø8x35	C1  20x 34 mm
D1  20x Ø15x12	D3  12x Ø17
E2  3x Ø3x20	E5  8x Ø3x30
F2  21x Ø3.5x15	G2  8x Ø4x15
G16  1x Ø4.5x55	F11  50x Ø3.5x17M
O19  8x Ø6.3x9	R7  4x
J2  4x M4x22	S18  2x GCHX GTV 300 mm
V25  4x Ø35 IE S	L1  2x
L15  1x 40x30x20	Q1  12x
H5  3x	X1  4x
H1  1x 1360 mm	H2  1x 468 mm
D25  2x Ø5/8	B10  1x Ø8x40

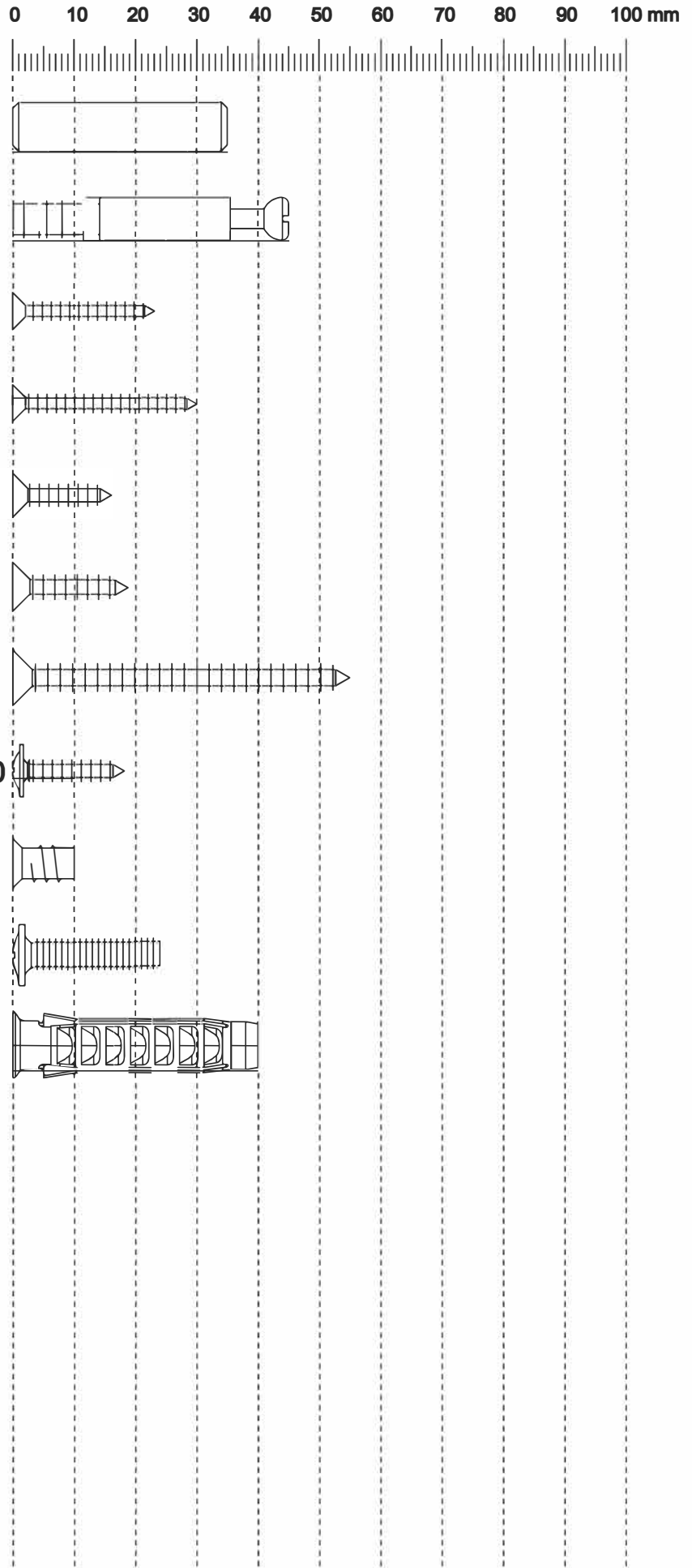

1 B1 x 16  

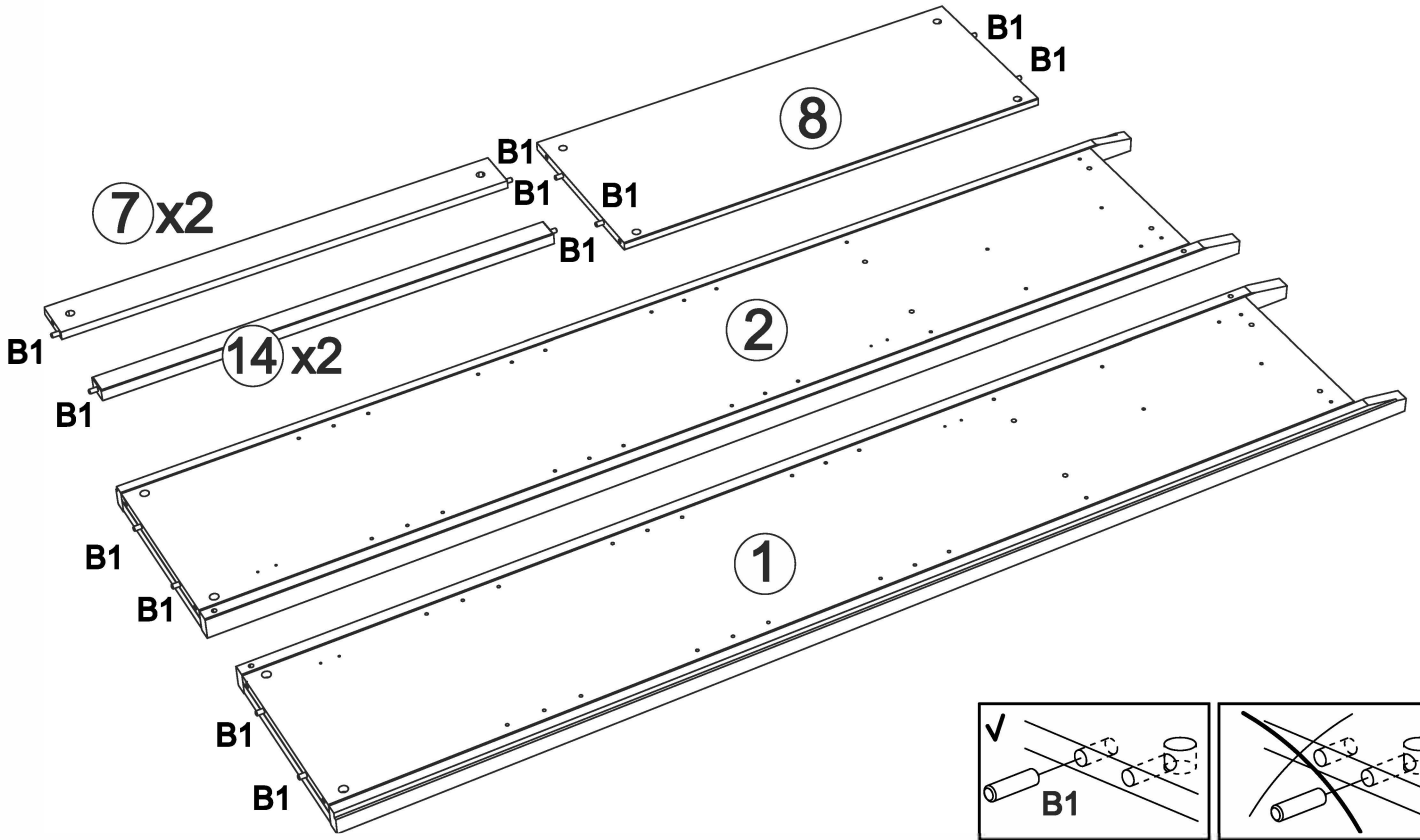

2 C1 x 12    PZ2

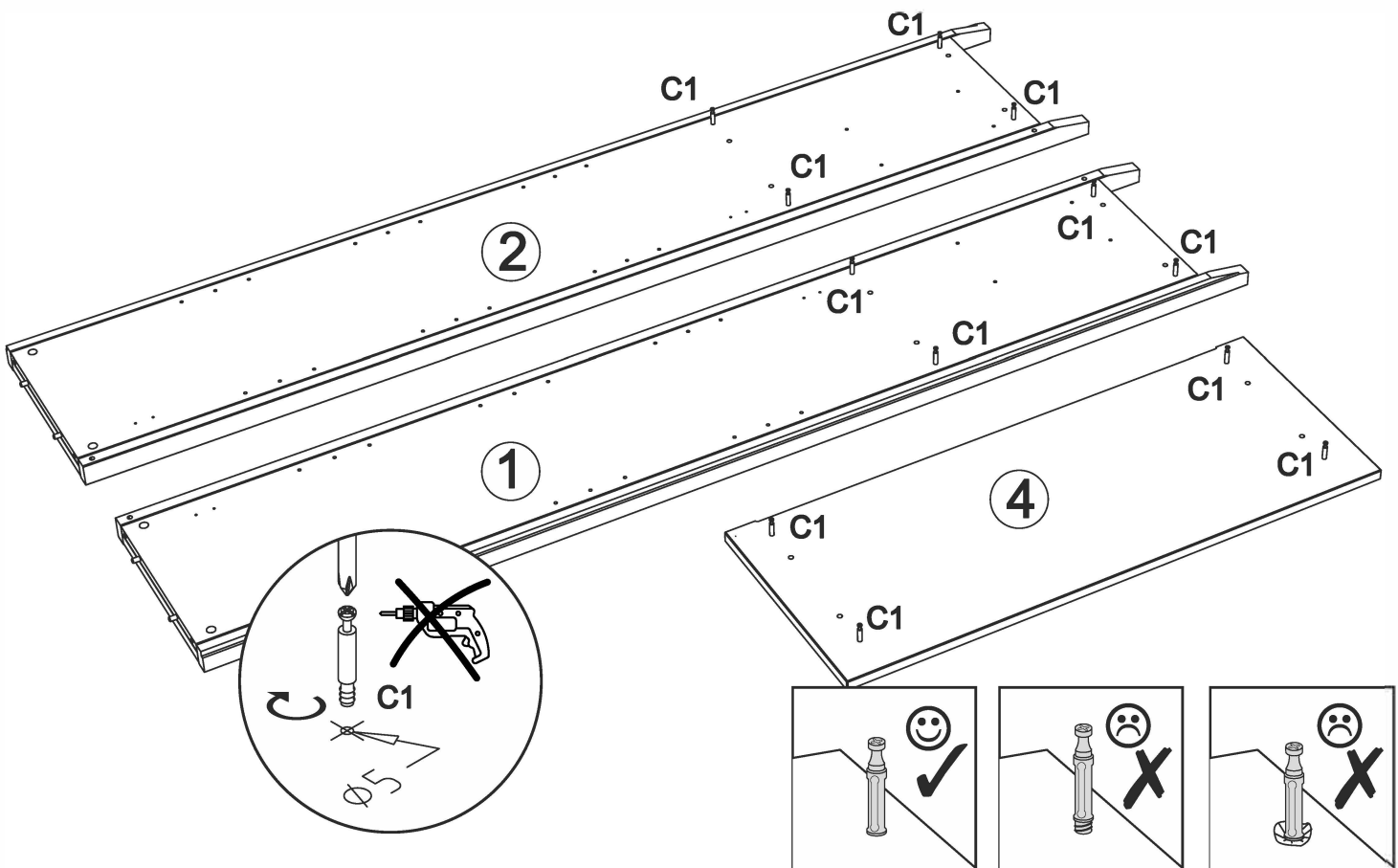

3

D1 x 8



PZ2

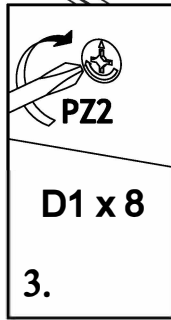
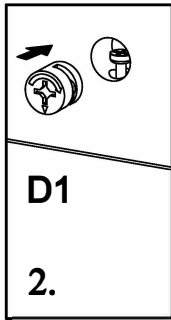
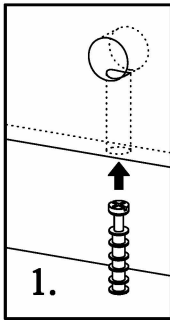
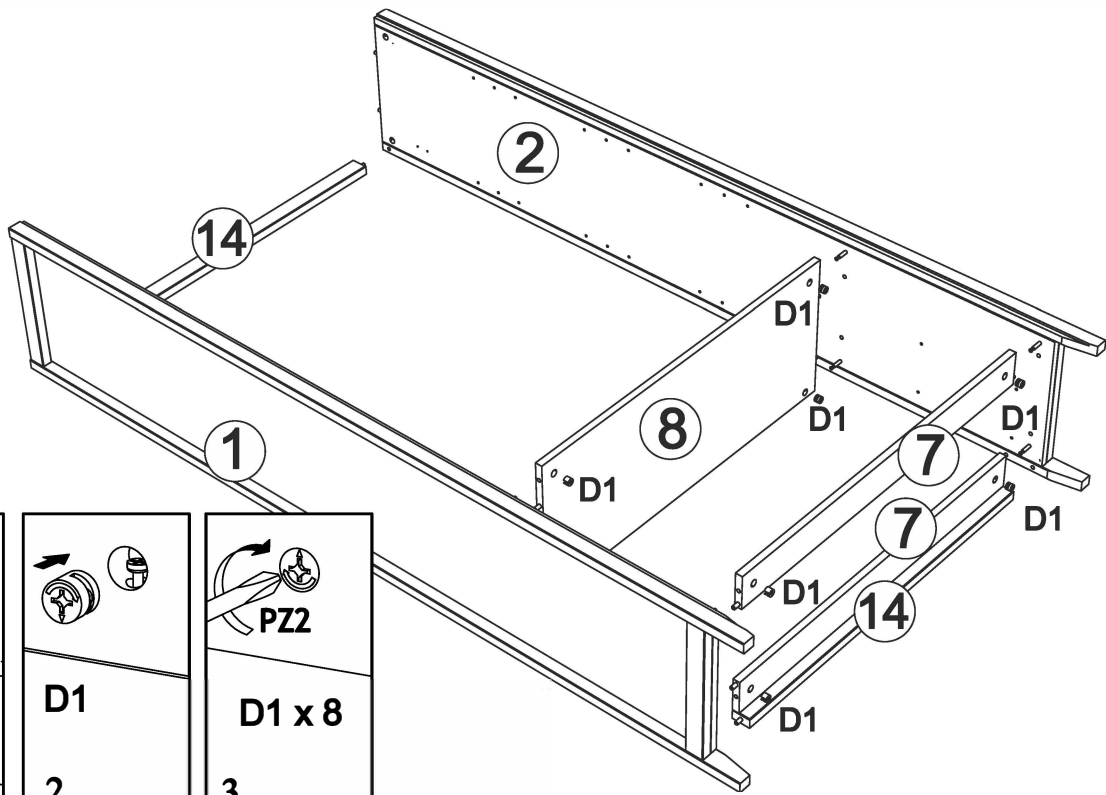

4

D1 x 4

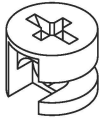

PZ2

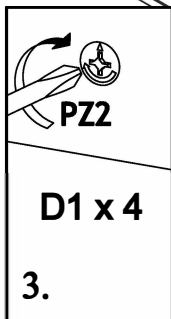
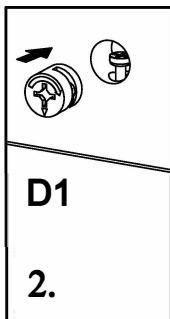
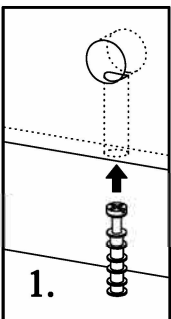
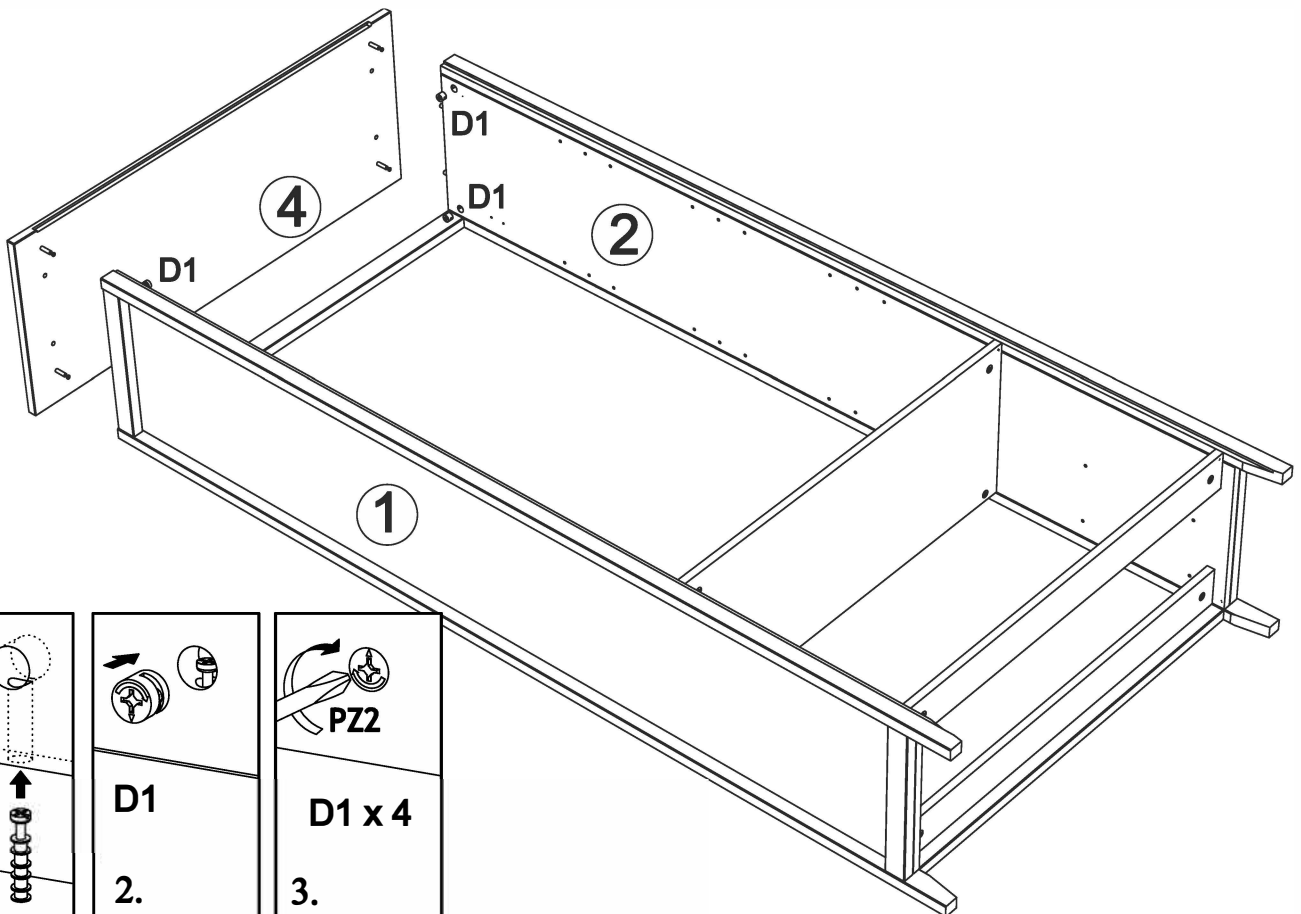

5

F2 x 4

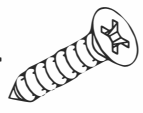

L1 x 2

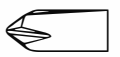

PZ2

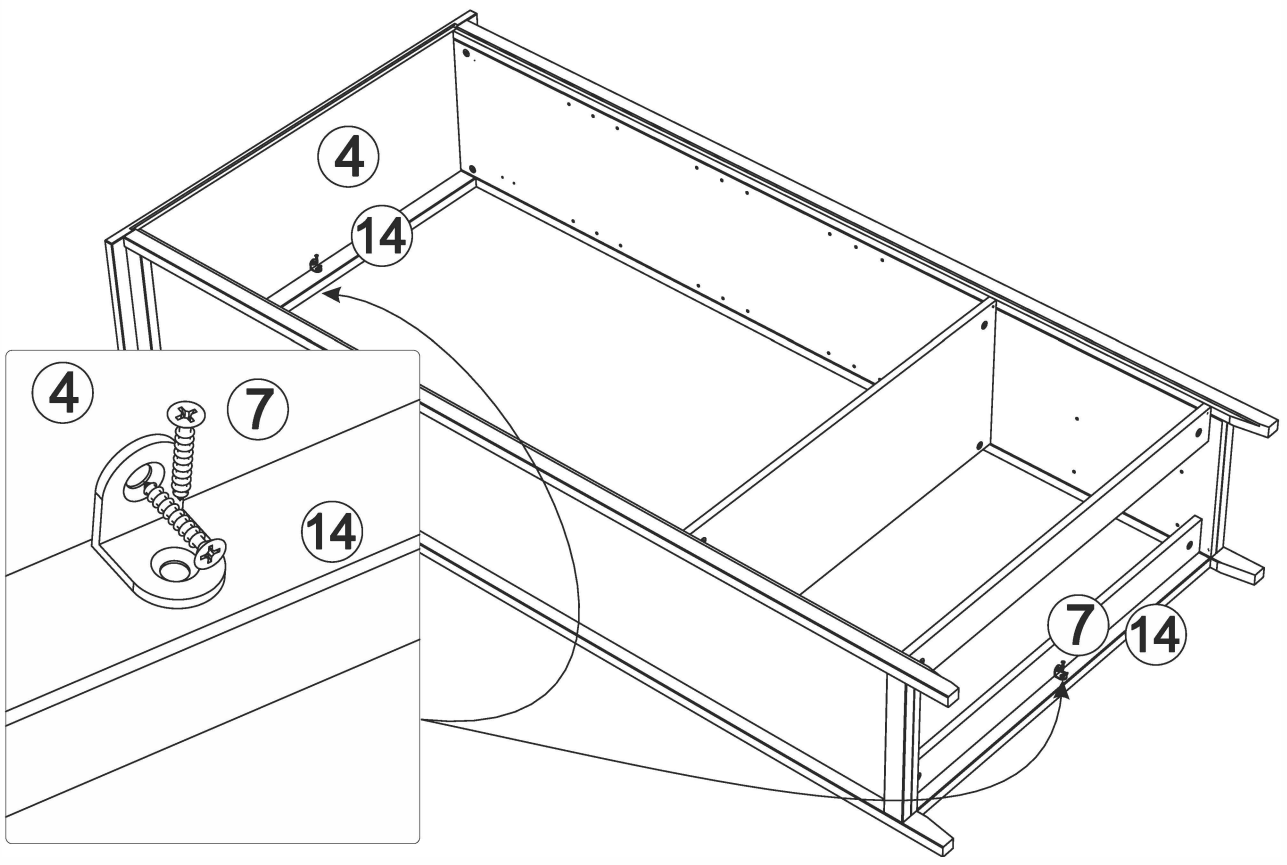

6

F11 x 40

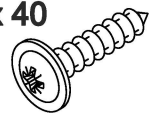

X1 x 4

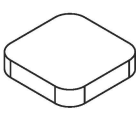

H1 x 1

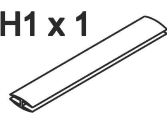

H2 x 1

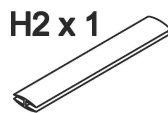

E2 x 3

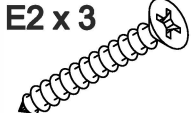

H5 x 3



X = Y

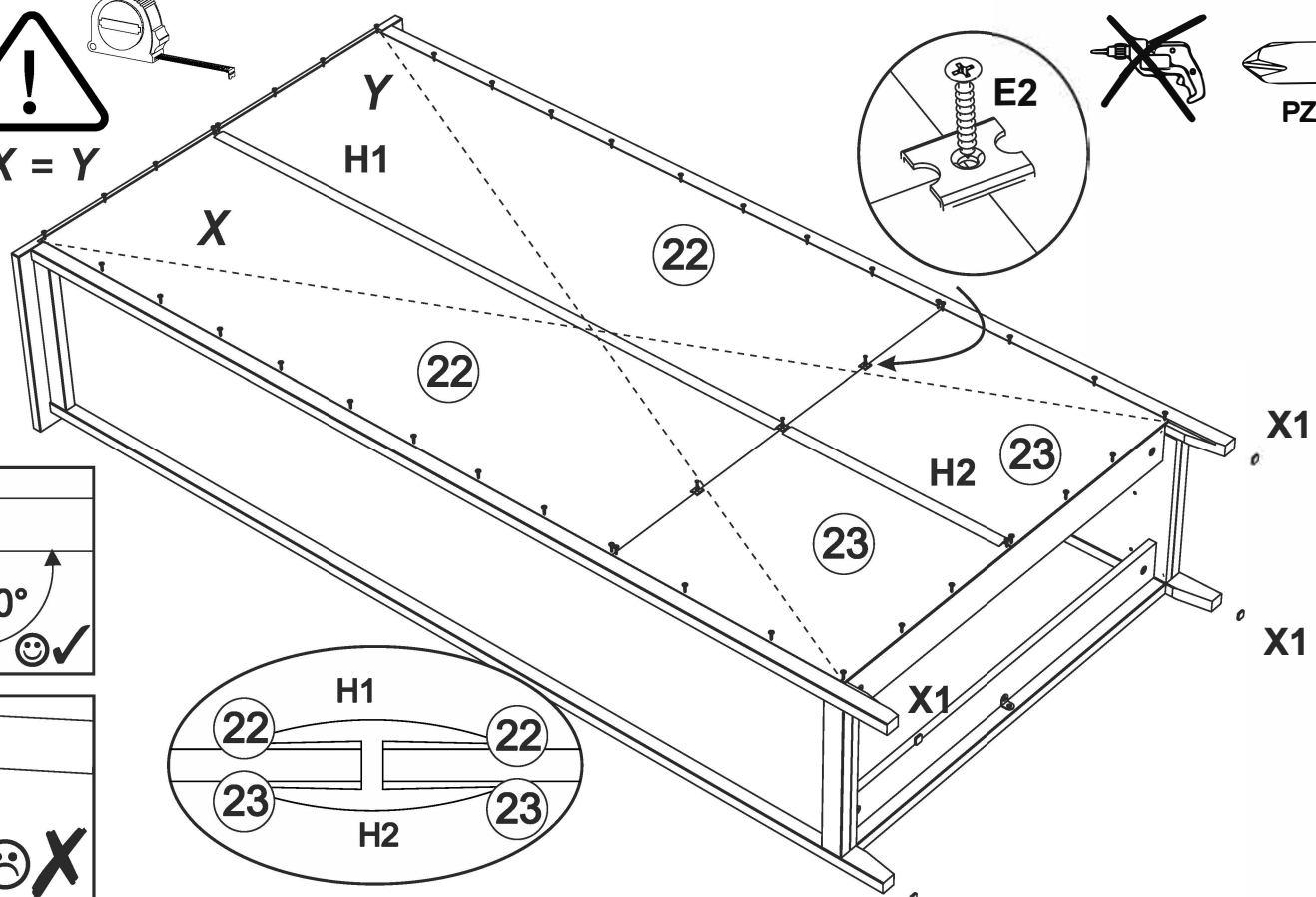

PZ2

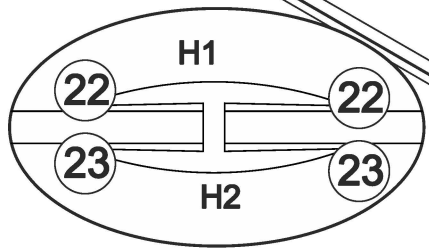
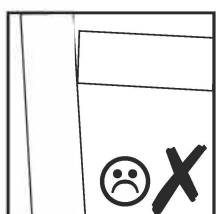
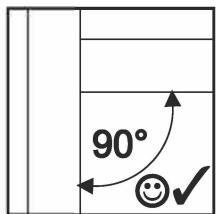

7

O1 x 8

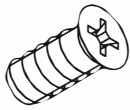

S18 x 2

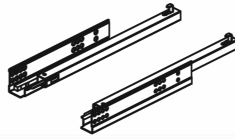

PZ2

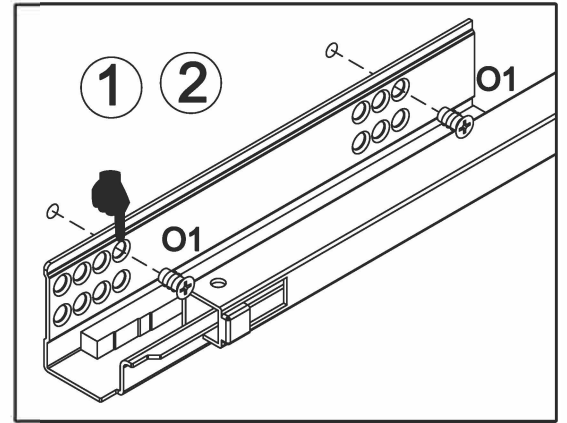
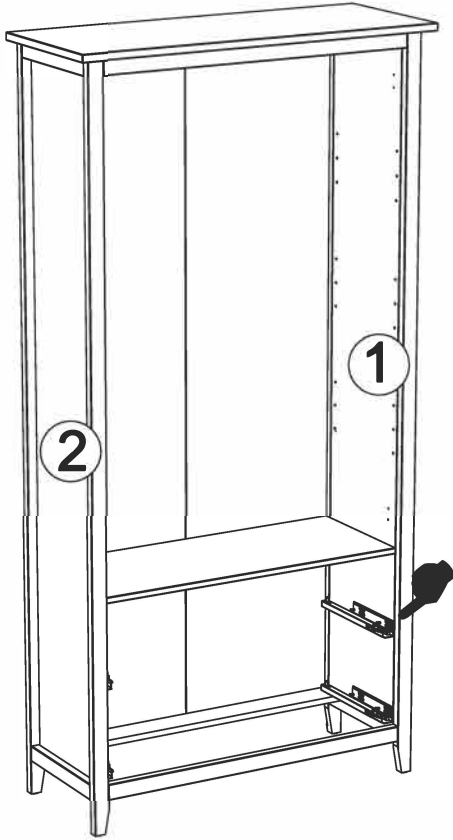

8

F2 x 8

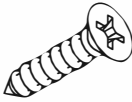

V25 x 4

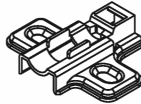

PZ2

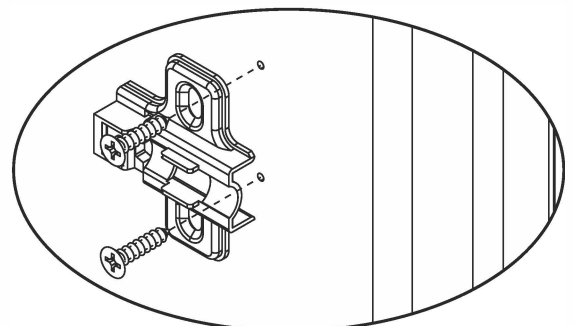
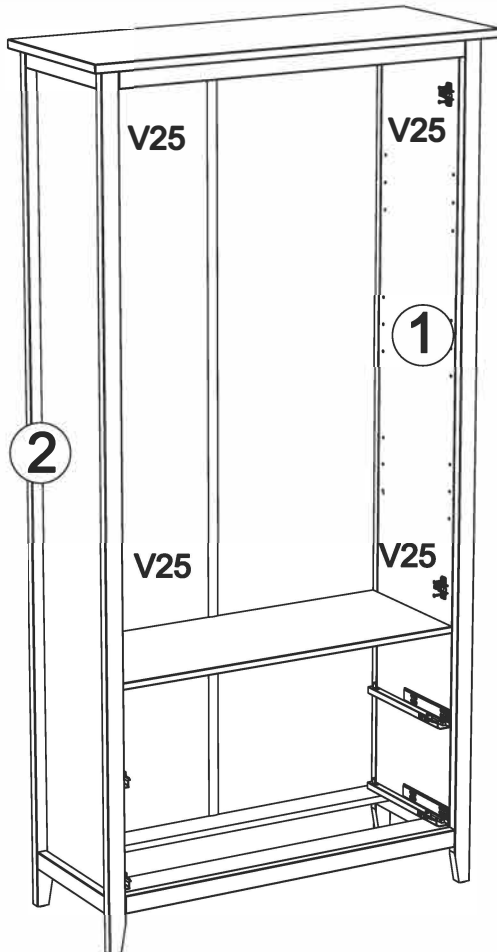

9

F2 x 1

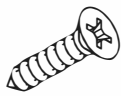

G16 x 1



B10 x 1

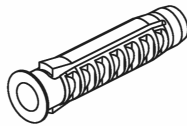

L15 x 1

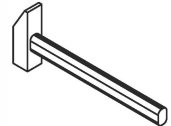

PZ2

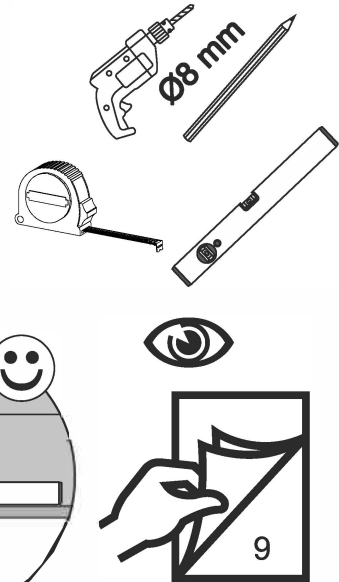
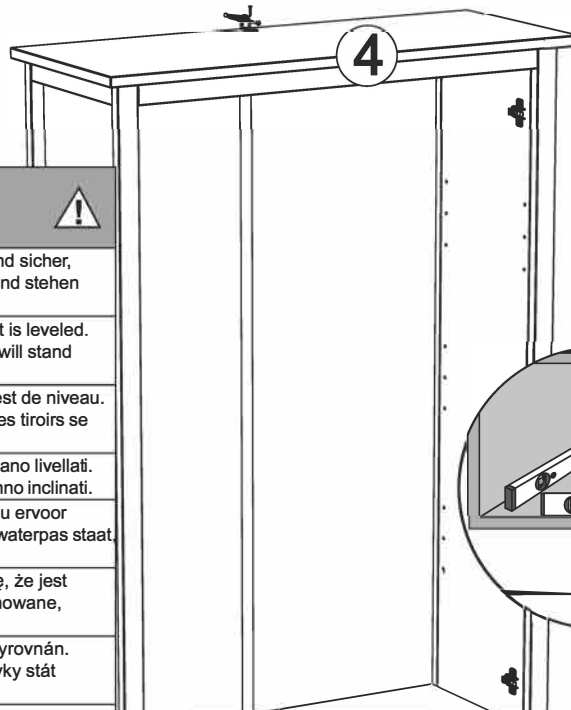

Achtung • Attention • Attenzione Opgelet • Uwaga • Pozor • Figyelem Atenție • Dikkat • Внимание	
D	Stellen Sie vor dem Anbringen der Möbel an der Wand sicher, dass sie eben sind. Wenn die Möbel nicht geebnet sind stehen die Türen und Schubladen schräg.
GB	Before attaching the furniture to the wall, make sure it is leveled. If the furniture is not leveled, the doors and drawers will stand at an skew.
FR	Avant de fixer le meuble au mur, assurez-vous qu'il est de niveau. Si les meubles ne sont pas de niveau, les portes et les tiroirs se tiendront en biais.
IT	Prima di fissare i mobili alla parete, assicurarsi che siano livellati. Se i mobili non sono livellati, le ante e i cassetti saranno inclinati.
NL	Voordat u het meubilair aan de muur bevestigt, moet u ervoor zorgen dat het waterpas staat. Als het meubilair niet waterpas staat staan de deuren en laden scheef.
PL	Przed przymocowaniem mebli do ściany upewnij się, że jest wypoziomowany. Jeśli meble nie zostaną wypoziomowane, drzwi i szuflady staną pod kątem.
CZ	Před připevněním nábytku ke zdi se ujistěte, že je vyrovnaný. Pokud není nábytek vyrovnaný, budou dveře a zásuvky stát zkosené.
SK	Pred pripavením nábytku na stenu sa uistite, že je vyrovnaný. Ak nábytek nebude vyrovnaný, dvere a zásuvky budú stát šikmo.
HU	Mielőtt a bútorkat a falhoz rögzíti, ellenőrizze, hogy azok el vannak-e állítva. Ha a bútor nincs kiegyenlítve, az ajtók és a fiókok ferdén állnak.
RO	Înainte de a fixa mobilierul pe perete, asigurați-vă că acesta este nivelat. În cazul în care mobilierul nu este nivelat, ușile și sertarele vor sta în picioare.
TR	Mobilyaları duvara bağlamadan önce, düz olduğundan emin olun. Mobilya düz değilse, kapılar ve çekmeceler eğik durur.
RU	Прежде чем прикреплять мебель к стене, убедитесь, что она выровнена. Если мебель не выровнена, двери и ящики будут стоять на перекосе.

Achtung • Attention • Attenzione Opgelet • Uwaga • Pozor • Figyelem Atenție • Dikkat • Внимание	
D	Wandbefestigung dient als Kippschutz – unbedingt anbringen! Bei einigen Wandtypen kann ein Spezialdübel erforderlich sein!
GB	The wall fastening serves to prevent tipping – be absolutely sure to mount it! For certain wall types, a special wall plug may be necessary!
FR	La fixation murale sert de protection contre le basculement – à installer impérativement ! Pour certains types de murs il faut des chevilles spéciales !
IT	Il fissaggio alla parete serve da protezione anti-ribaltamento – attaccarla assolutamente! Per alcune strutture di parete può essere necessario un tassello speciale!
NL	Bevestiging aan de muur dient als kantelbescherming – zeker en vast bevestigen! Bij enkele muurtypen is een speciale plug misschien vereist!
PL	Mocowanie do ściany jest jednocześnie zabezpieczeniem przed przewróceniem – koniecznie zamontować! Do niektórych rodzajów ścian koniecznie zastosować specjalne kołki mocujące.
CZ	Montáž na stěnu slouží jako ochrana proti převrnutí – bezpodmínečně umístěte! U některých typů stěn může být zapotřebí speciální hmoždinka!
SK	Upevnenie na stenu slúži ako ochrana proti prevráteniu – bezpodmienenčne použite! Pre niektoré druhy stien môže byť potrebná špeciálna hmoždinka!
HU	A termékét a falhoz rögzíteni, különben az felborulhat! Egyes faltípusoknál speciális tiplőt kell használni!
RO	Sistemul de fixare la perete servește ca protecție la răsturnare – de montat obligatoriu! Pentru unele tipuri de pereți este posibil să fie necesar un diblu special!
TR	Duvardaki sabitleme, devrilmeye karşı bir emniyet tedbiridir ve mutlaka monte edilmelidir! Bazı duvar tiplerinde bunun için özel bir dübel gerekli olabilir!
RU	Обязательно установите крепление на стене во избежание опрокидывания! Для некоторых типов стен может потребоваться специальный дюбель!

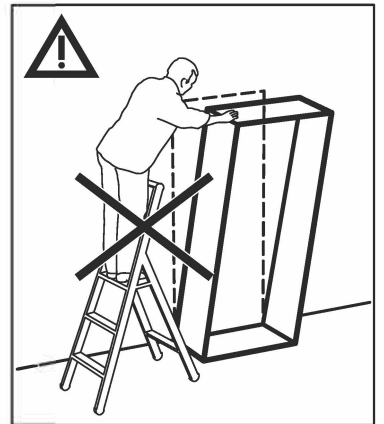

D	Das beigefügte Wandbefestigungsmaterial (Dübel und Schrauben) eignet sich nur für festes Mauerwerk (z.B. Beton- oder Ziegelwände). Für andere Wandbauten sind eventuell Spezialdübel und andere Schrauben notwendig. Ziehen Sie gegebenenfalls eine Fachkraft zurate.
GB	The enclosed wall mounting materials (dowels and screws) are only suitable for solid masonry (e. g. concrete or brick walls). Special dowels and other screws may be necessary for other wall constructions. If necessary, please consult a qualified professional.
FR	Le matériel de fixation murale fourni (chevilles et vis) convient uniquement à des murs solides (p. ex. murs en béton ou en briques). Pour les autres constructions de murs, il faut éventuellement des chevilles spéciales et d'autres vis. Faites-vous conseiller par un spécialiste.
IT	I materiali di fissaggio allegati (tasselli e viti) sono adatti solo ai muri compatti (ad es. di calcestruzzo o mattoni). Per altri tipi di pareti è probabile che occorrano tasselli speciali e altre tipologie di viti. Richiedere eventualmente il consiglio di un esperto.
NL	Het bijgeleverde bevestigingsmateriaal (pluggen en schroeven) is geschikt voor vaste muren (bijv. betonnen of bakstenen muren). Voor andere muurconstructies zijn eventueel speciale pluggen en andere schroeven noodzakelijk. Consulteer eventueel een vakman.
PL	Załączony zestaw montażowy do zamocowania artykułu do ściany (kołki, wkrety, haki itp.), przeznaczony jest wyłącznie do montażu artykułu na ścianach wykonanych z cegły lub betonu. Przy montażu artykułu na ścianie wykonanej z innych materiałów, należy zastosować odpowiednie do niej zamocowania. W razie wątpliwości prosimy zasięgnąć porady fachowca.
CZ	Přiložený materiál pro montáž na stěnu (hmoždinky a šrouby) je vhodný jen pro pevné zdivo (např. betonové nebo cihlové stěny). Pro jiné skladby stěn budou případně nutné speciální hmoždinky a jiné šrouby. Poradte se případně s odborníkem.
SK	Přiložený materiál pre upevnenie na stenu (hmoždinky a skrutky) je vhodný len pre pevné murivo (napr. betónové alebo tehlové steny). Pre iné steny sú potrebné príp. špeciálne hmoždinky a iné skrutky. V prípade potreby sa poradte s odborníkom.
HU	A mellékelt fal rögzítőkészlet (tiplé és csavarok) csak tömött falazatban (pl. betonfalban, téglafalban) használható. Más faltípusokhoz speciális tiplire és csavarra lesz szükség. Szükség esetén kérje ki egy szakember véleményét.
RO	Materialul furnizat pentru montajul de perete (dibluri și șuruburi) este adecvat numai pentru zidărie solidă (de exemplu pereți din beton sau din cărămidă). Pentru alte structuri de pereți, este posibil să fie necesare dibluri speciale, precum și alte șuruburi. Dacă este necesar, consultați un specialist.
TR	Teslimat kapsamındaki duvar tipi sabitleme materyali (dübel ve vidalar) sadece beton ve tuğla duvarın gibi sağlam duvar yapıları için uygundur. Başka duvar yapıları için özel dübeller veya başka vidalar gerekli olabilir. Gerekirse bir uzmandan yardım alın.
RU	Входящий в комплект поставки материал для крепления на стене (дюбели и болты) предназначен только для прочных каменных стен (например, бетонных или кирпичных). Для других типов стен используйте по мере необходимости специальные дюбели и другие болты. По мере необходимости обратитесь за помощью к специалистам.

1.

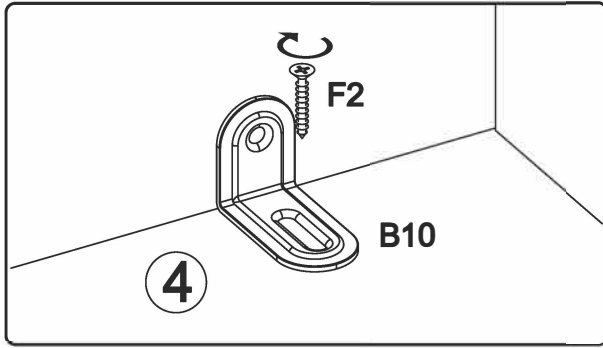

2.

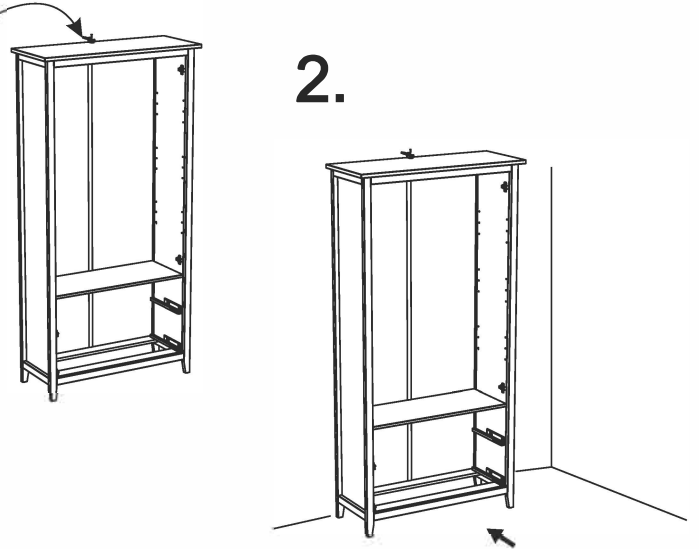

3.

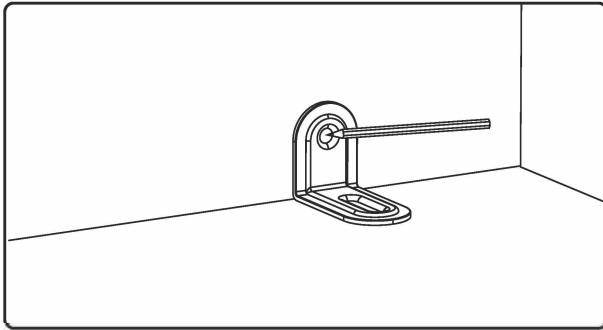

4.

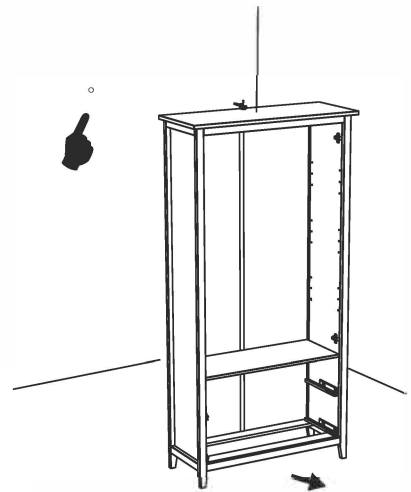

6.

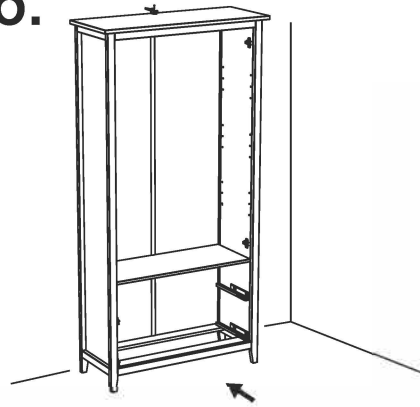

5.

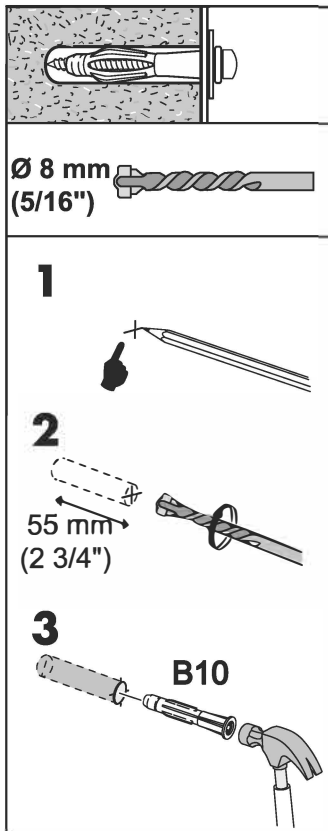

7.

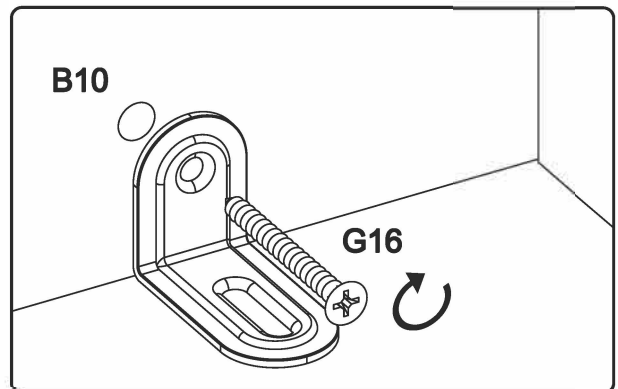

10

B1 x 4

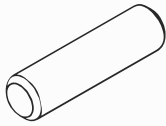

C1 x 8

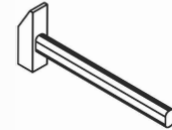
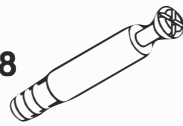

PZ2

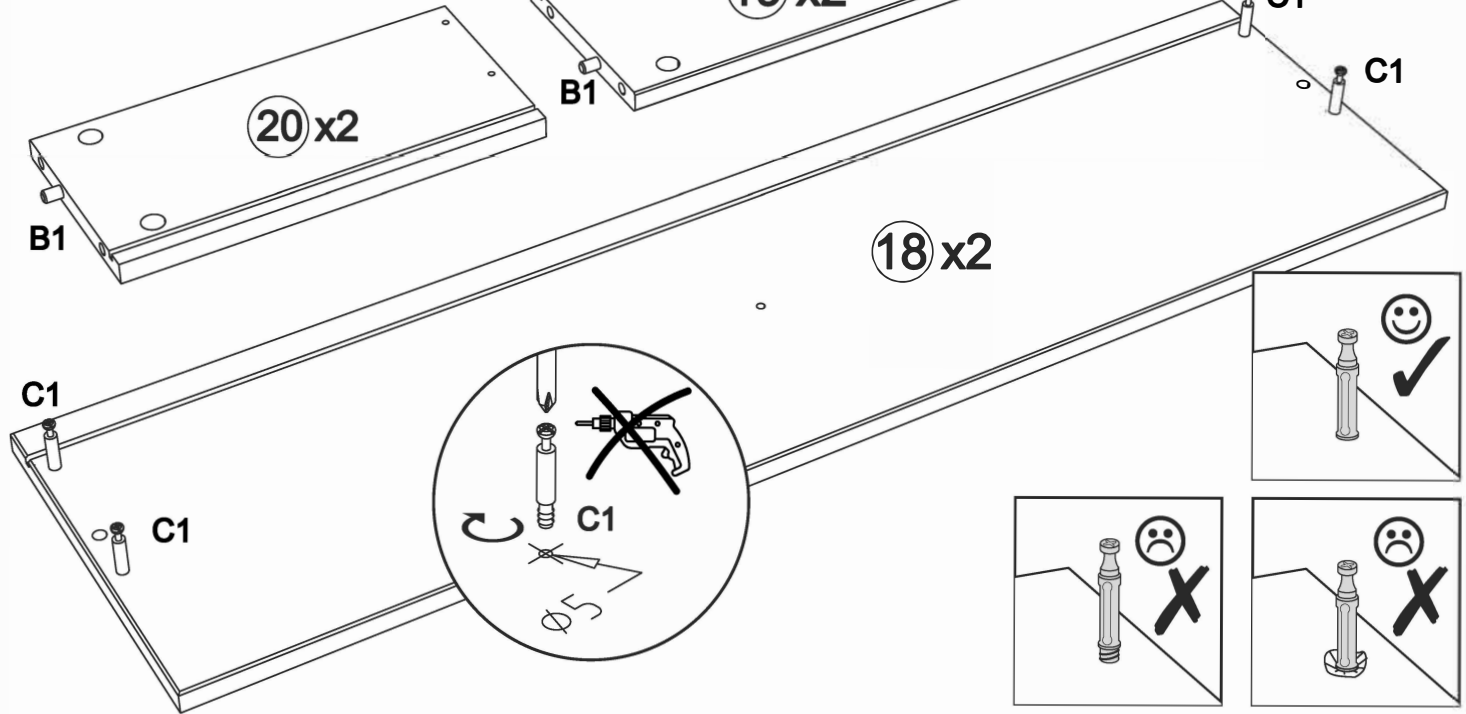
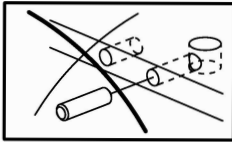
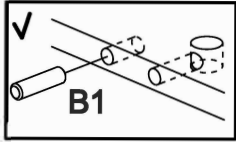

11

E5 x 8

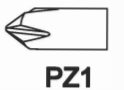
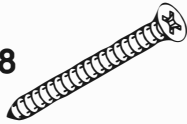

PZ1

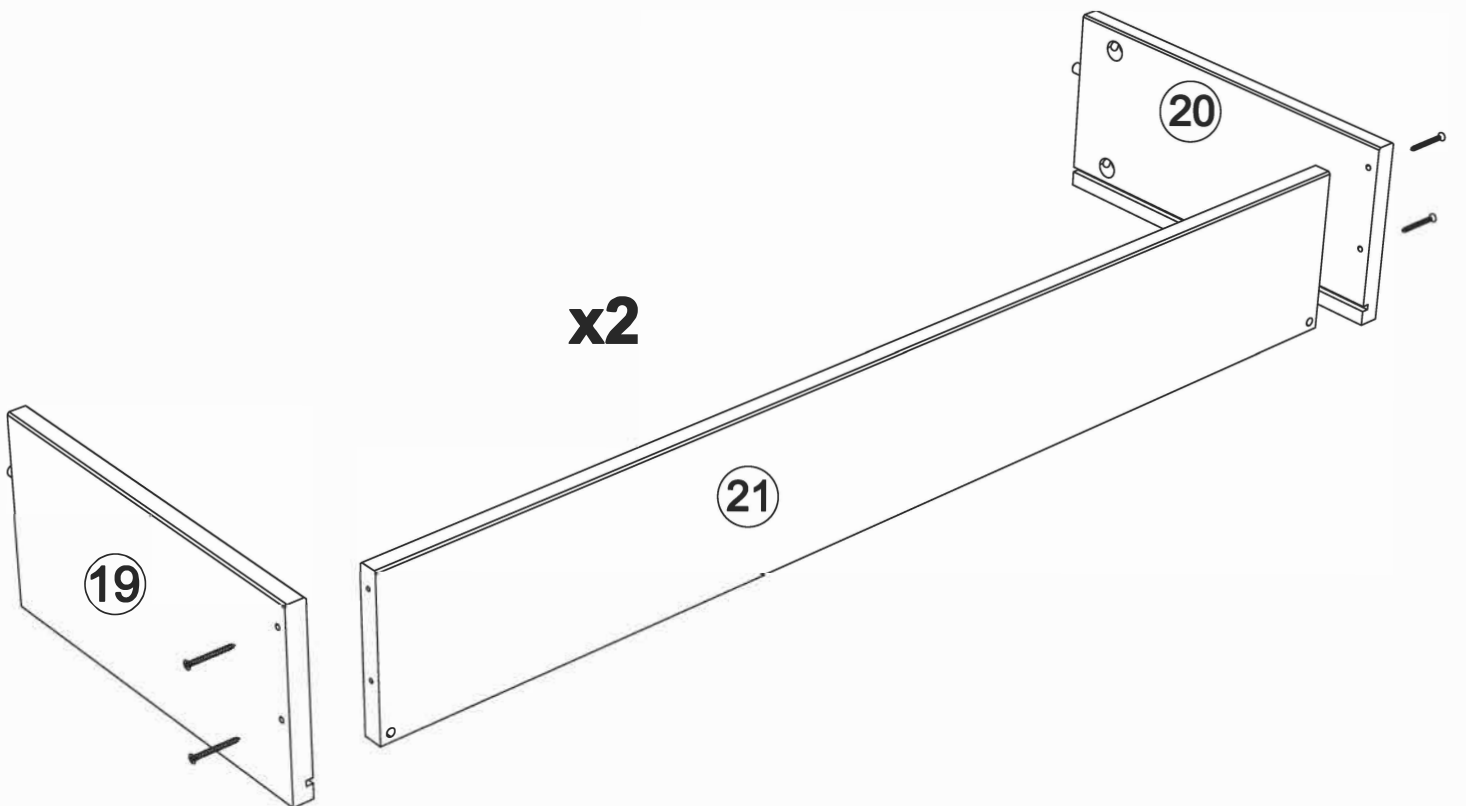

12

D1 x 8



D3 x 8

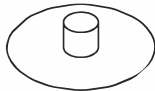

PZ2

x2

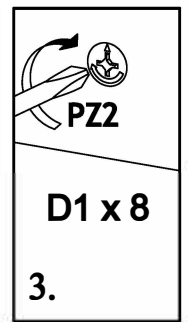
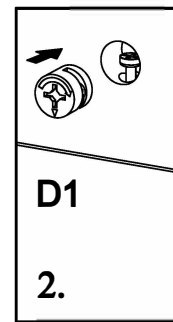
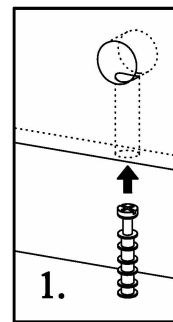
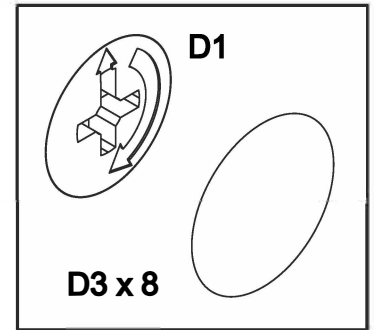
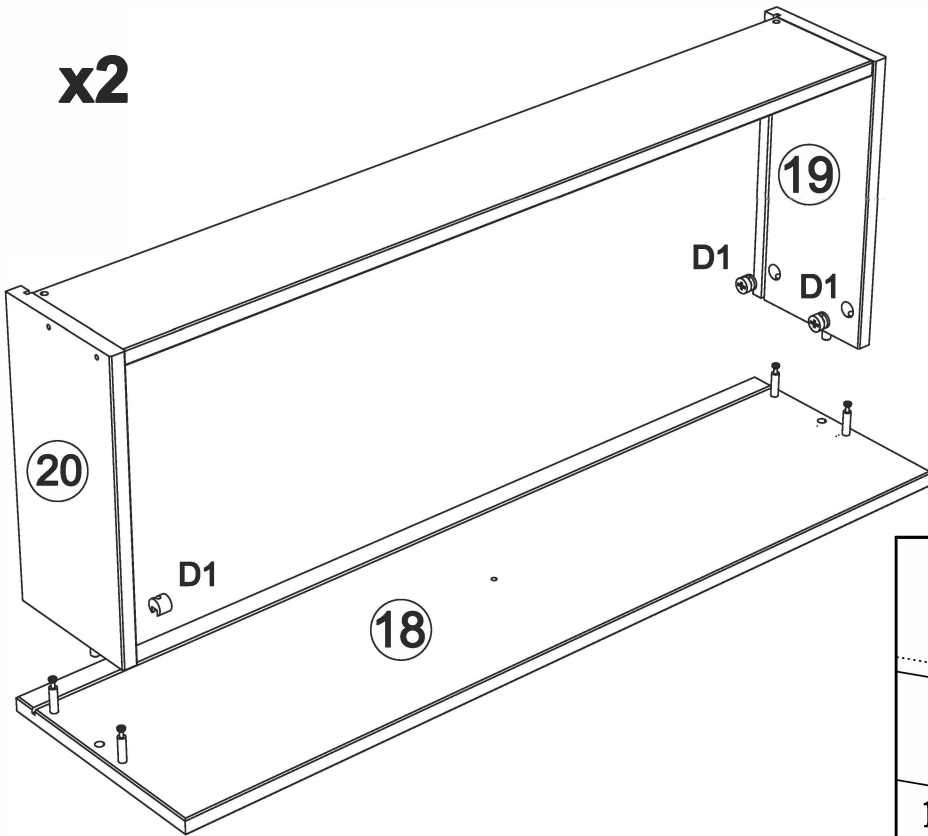

13

F11 x 10

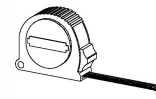
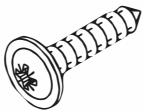

PZ2

x2

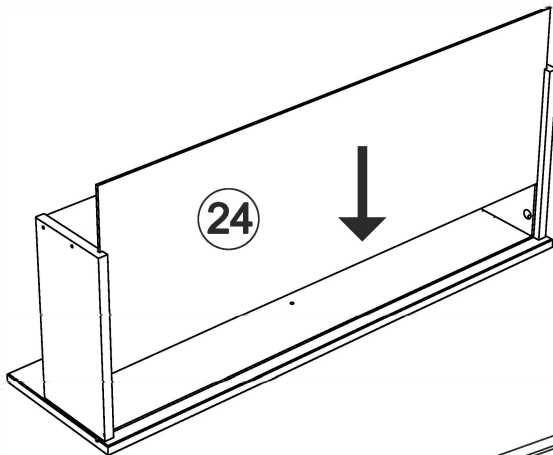

X = Y

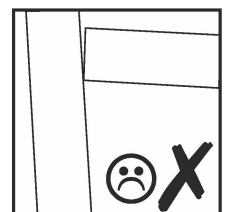
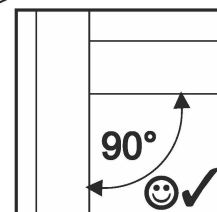
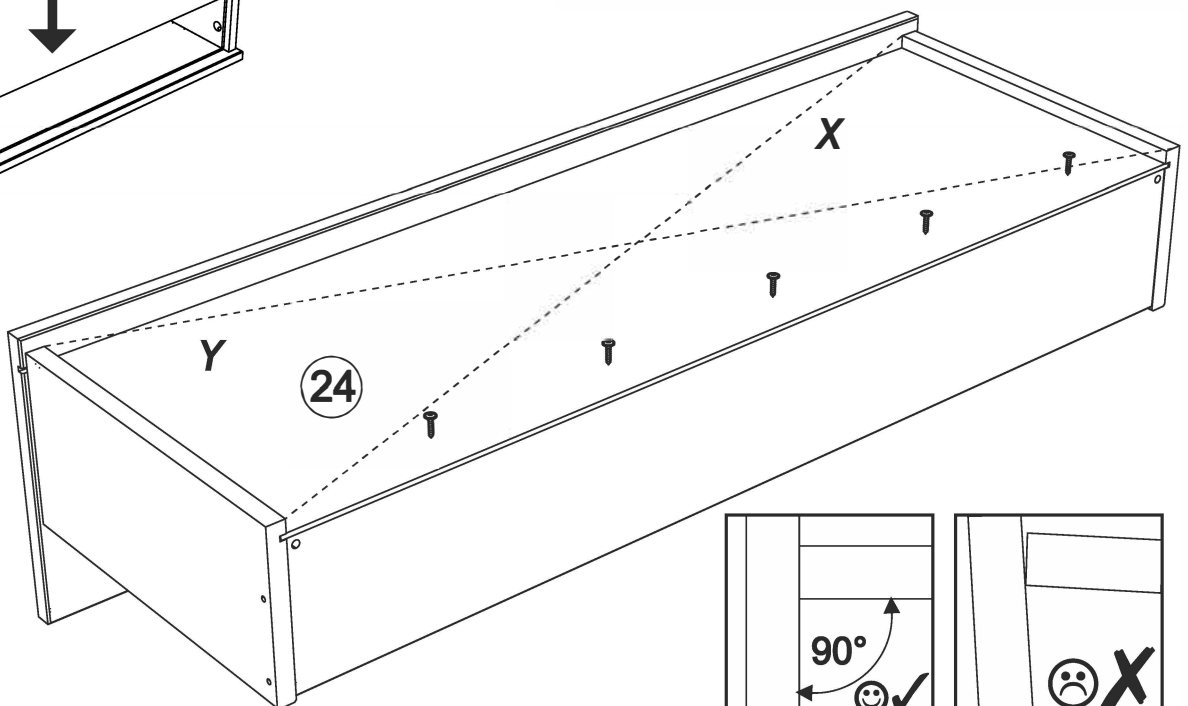

14

S18 x 2

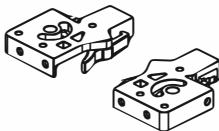

G2 x 8

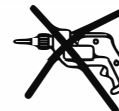

PZ2

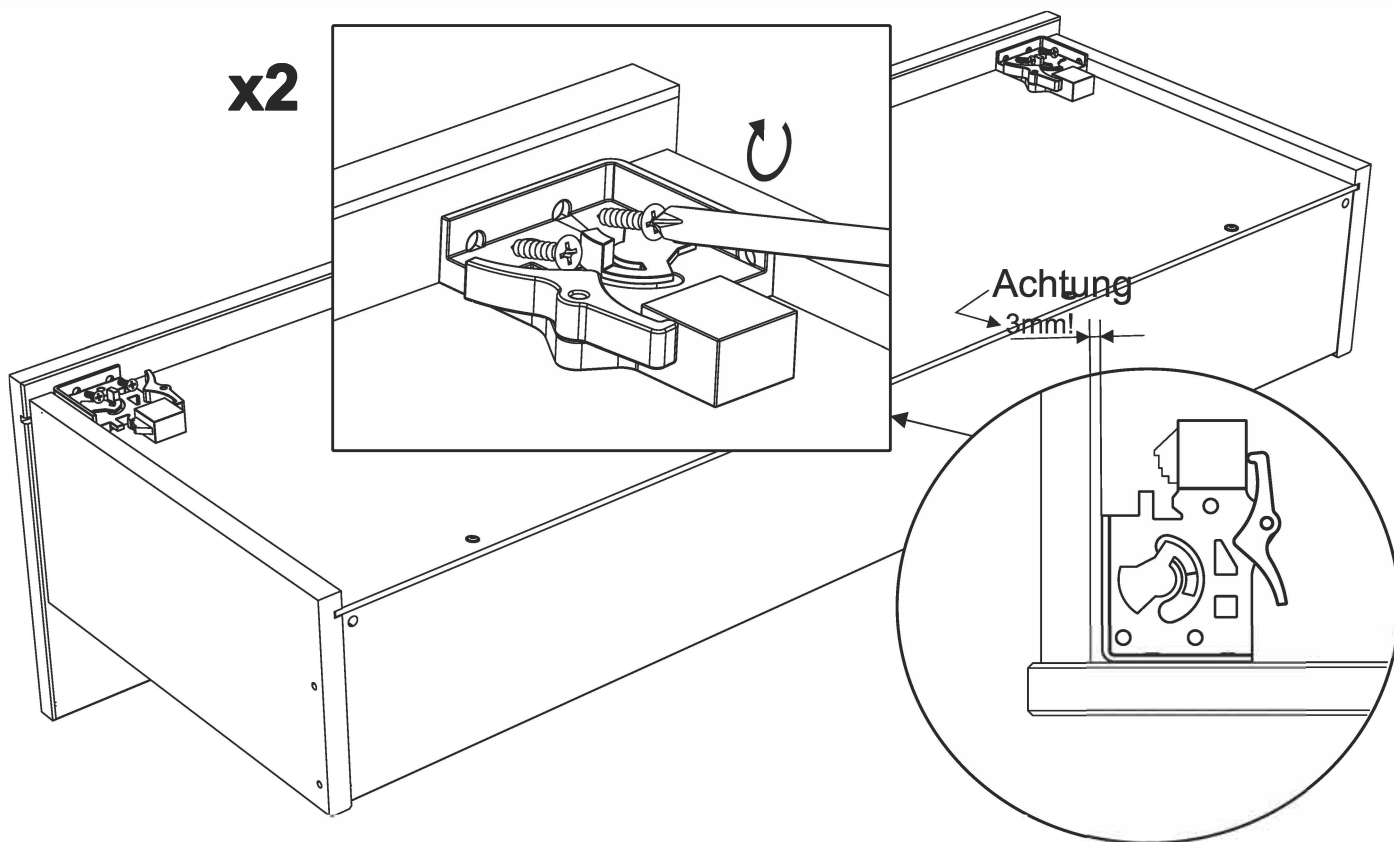

15

R7 x 2



J2 x 2

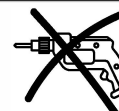
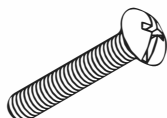

PZ2

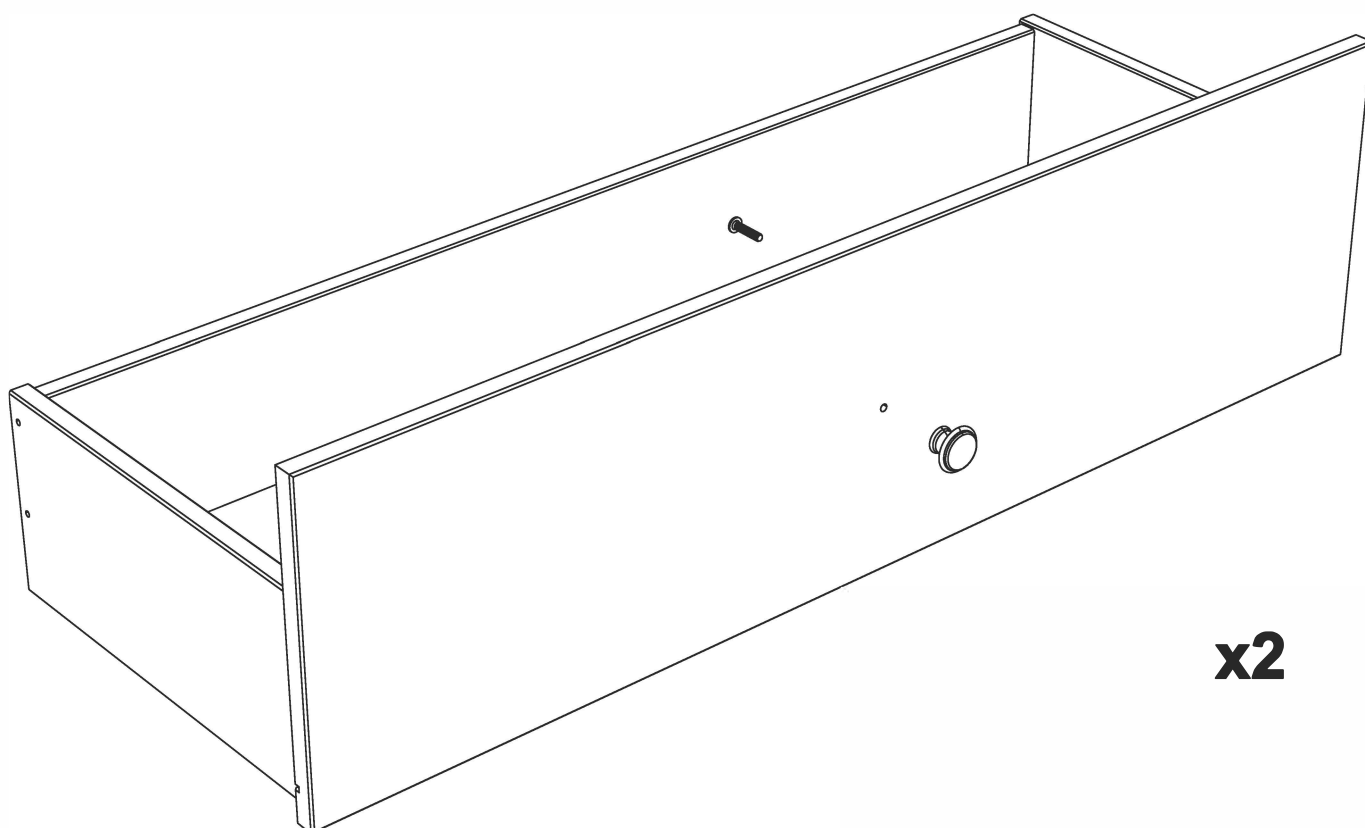

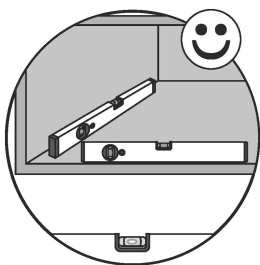
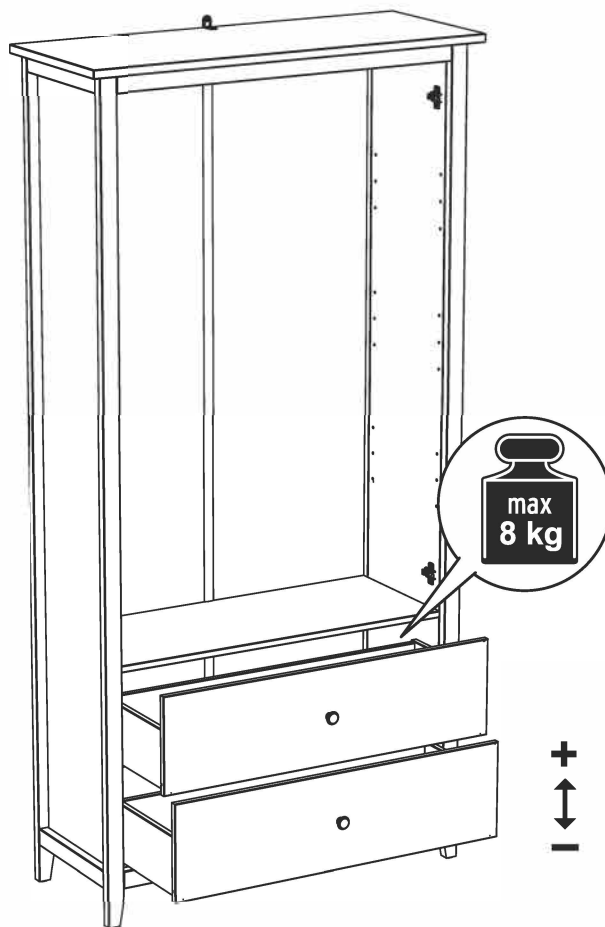

Achtung • Attention • Attenzione Opgelet • Uwaga • Pozor • Figyelem Atenție • Dikkat • Внимание	
	Stellen Sie sicher, dass die Möbel eben sind. Wenn die Möbel nicht ausgerichtet sind, funktionieren die Schubladen möglicherweise nicht richtig, haften und brechen die Führungen.
	Make sure the furniture is level. If the furniture is not aligned, the drawers may not work properly, clinging, and breaking the guides.
	Assurez-vous que les meubles sont de niveau. Si les meubles ne sont pas alignés, les tiroirs peuvent ne pas fonctionner correctement, s'accrocher et casser les guides.
	Assicuratevi che i mobili siano in piano. Se i mobili non sono allineati, i cassetti potrebbero non funzionare correttamente, aderendo e rompendo le guide.
	Zorg ervoor dat het meubilair waterpas staat. Als het meubilair niet is uitgelijnd, werken de lades mogelijk niet goed, kleven ze vast en breken ze de geleiders.
	Upewnij się, że meble są wypoziomowane. Jeśli meble nie są wyrównane, szuflady mogą nie działać prawidłowo, przywierając i łamiąc prowadnice.
	Ujistěte se, že je nábytek ve vodorovné poloze. Pokud nábytek není zarovnaný, zásuvky nemusí fungovat správně, držet se a porušovat vodítka.
	Skontrolujte, či je nábytek vo vodorovnej polohe. Ak nábytek nie je zarovnaný, zásuvky musia správne fungovať, držať sa a zlomiť vodítka.
	Ellenőrizze, hogy a bútorok vízszintesek-e. Ha a bútor nem igazodik, előfordulhat, hogy a fiókok nem működnek megfelelően, beragadhatnak és eltörhetnek a vezetőket.
	Asigurați-vă că mobila este la nivel. Dacă mobilierul nu este aliniat, sertarele pot să nu funcționeze corect, să se agațe și să spargă ghidajele.
	Mobilyaların düz olduğundan emin olun. Mobilyalar hizalı değilse, çekmeceler düzgün çalışmayabilir, kılavuzları yapıştırebilir ve kırabilir.
	Убедитесь, что мебель ровная. Если мебель не выровнена, ящики могут не работать должным образом, цепляясь и ломая направляющие.

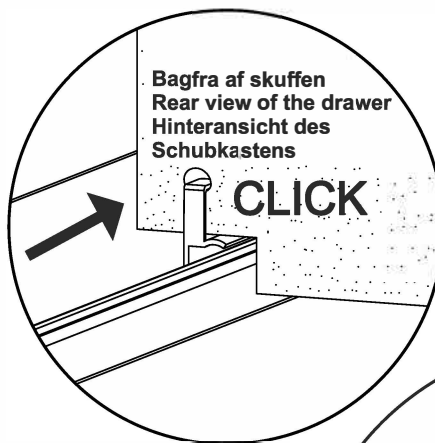

CLICK

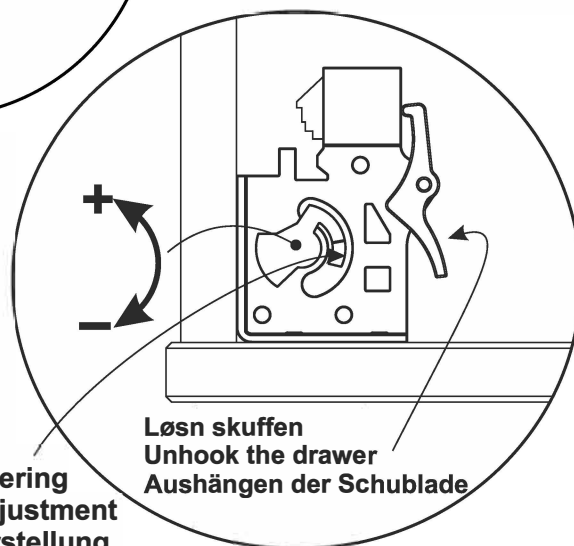

Højdejustering
Height adjustment
Höhenverstellung

17

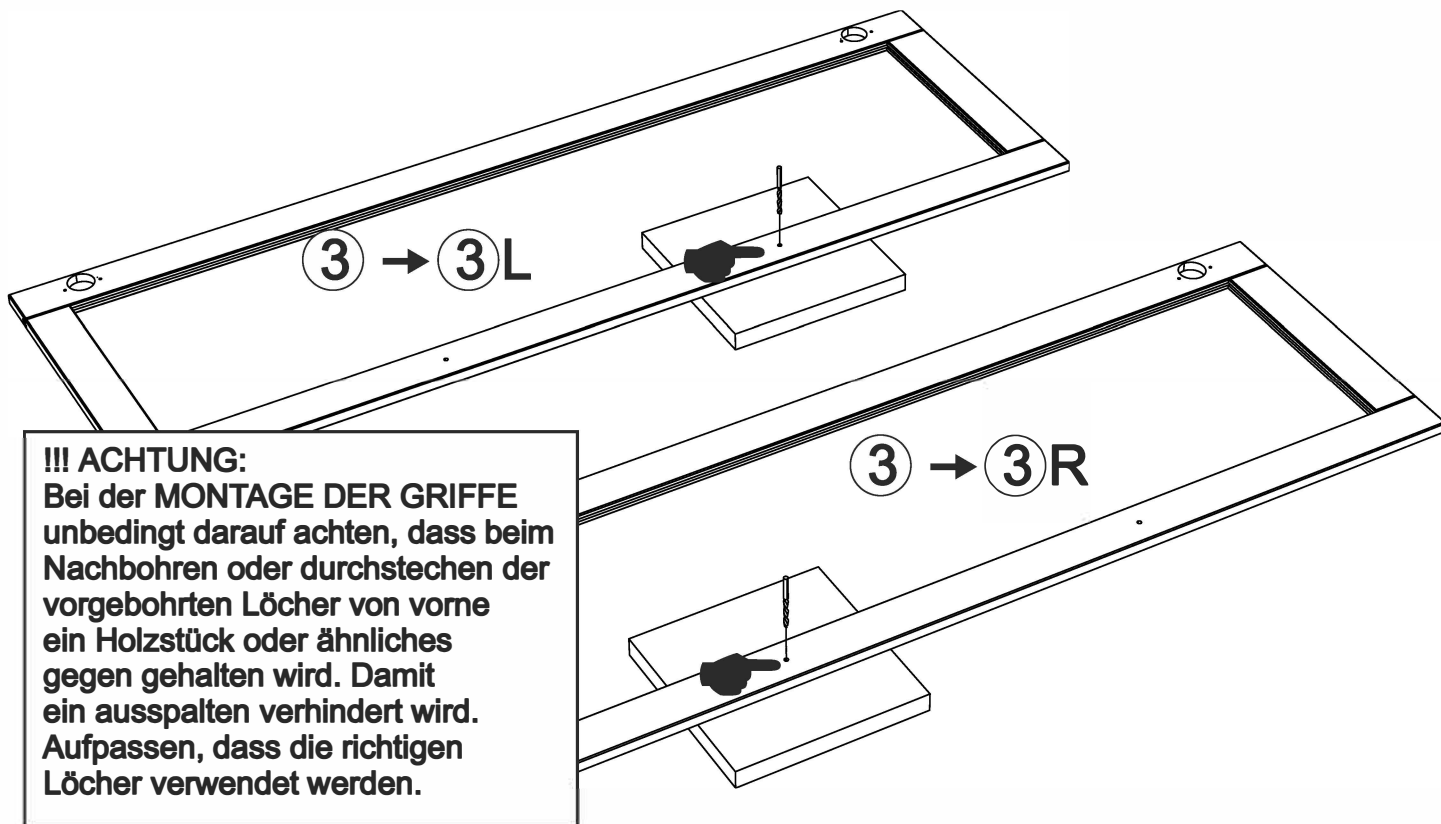
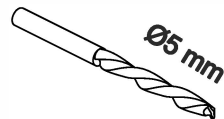

!!! ACHTUNG:
Bei der MONTAGE DER GRIFFE
unbedingt darauf achten, dass beim
Nachbohren oder durchstechen der
vorgebohrten Löcher von vorne
ein Holzstück oder ähnliches
gegen gehalten wird. Damit
ein ausspalten verhindert wird.
Aufpassen, dass die richtigen
Löcher verwendet werden.

18

F2 x 8

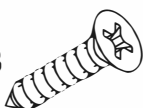

V25 x 4

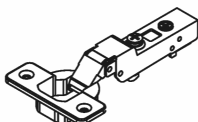

PZ2

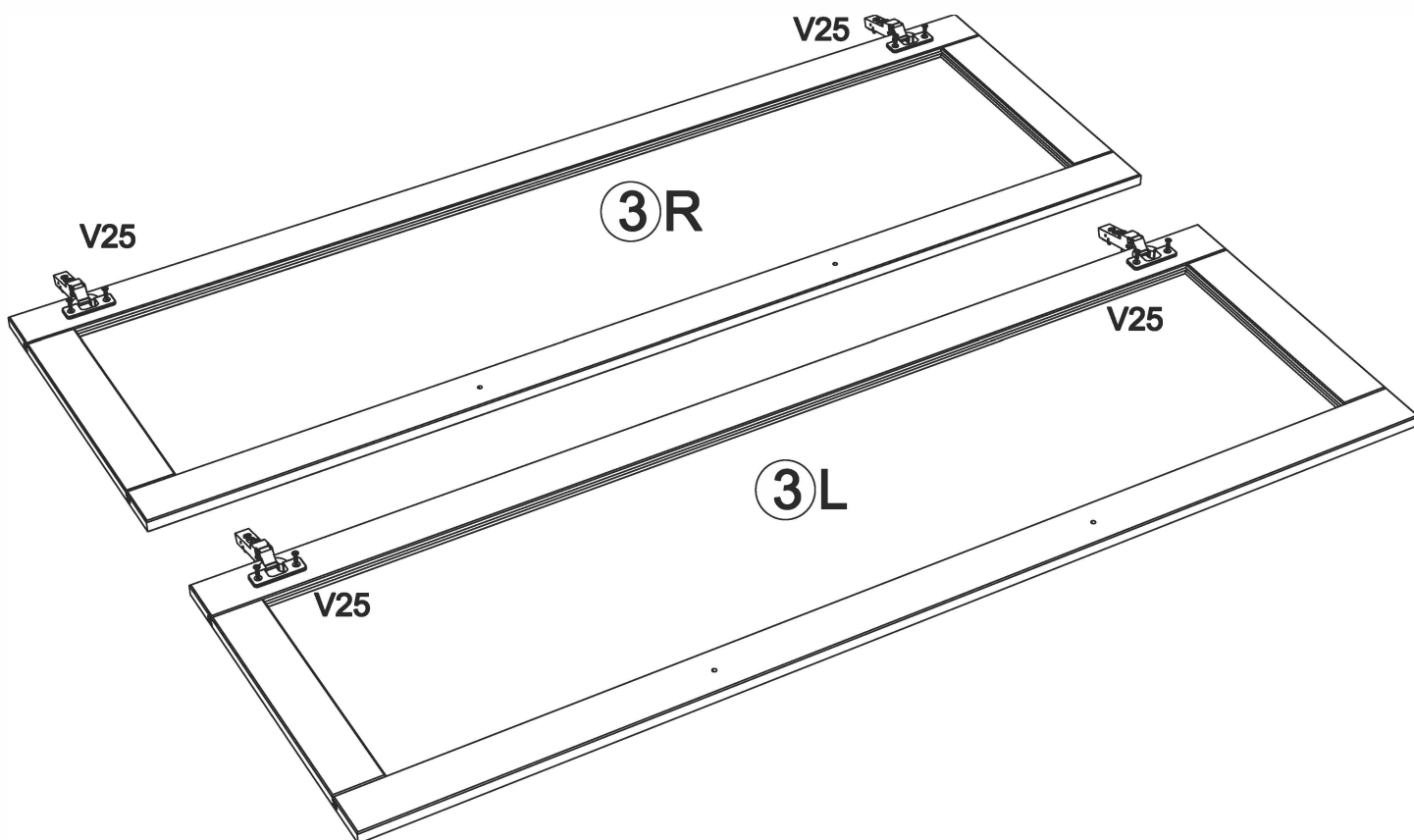

19

D25 x 2

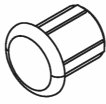

R7 x 2

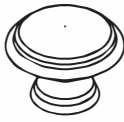

J2 x 2

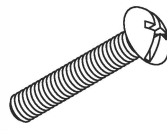

PZ2

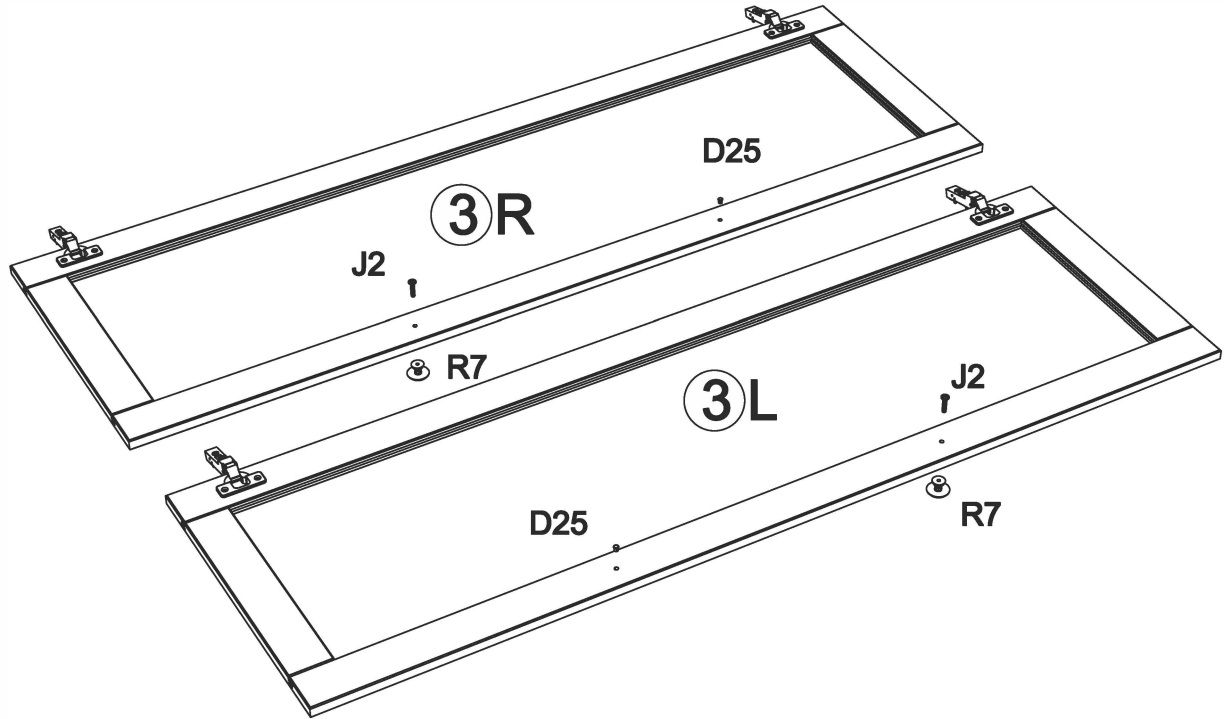

20

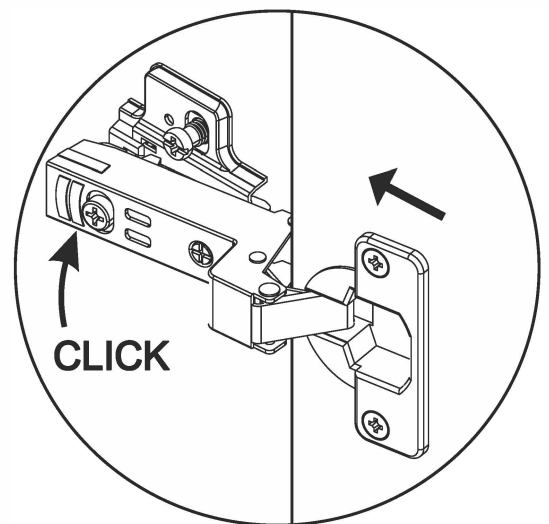
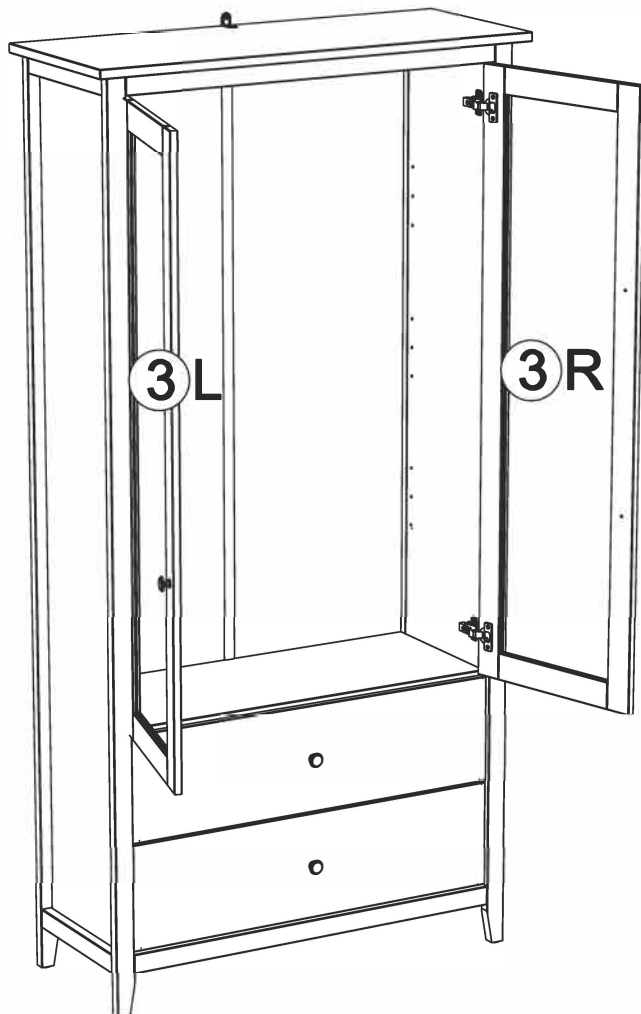

21

V25 x 4

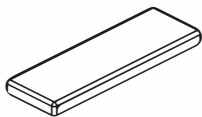

Q1 x 12



D3 x 4

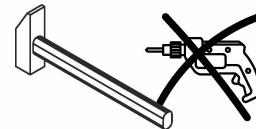
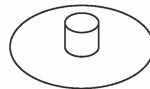

PZ2

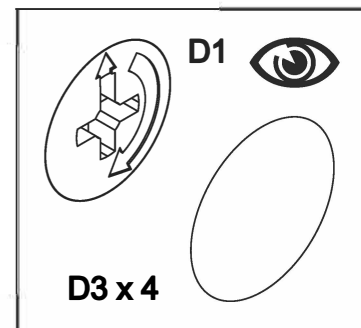
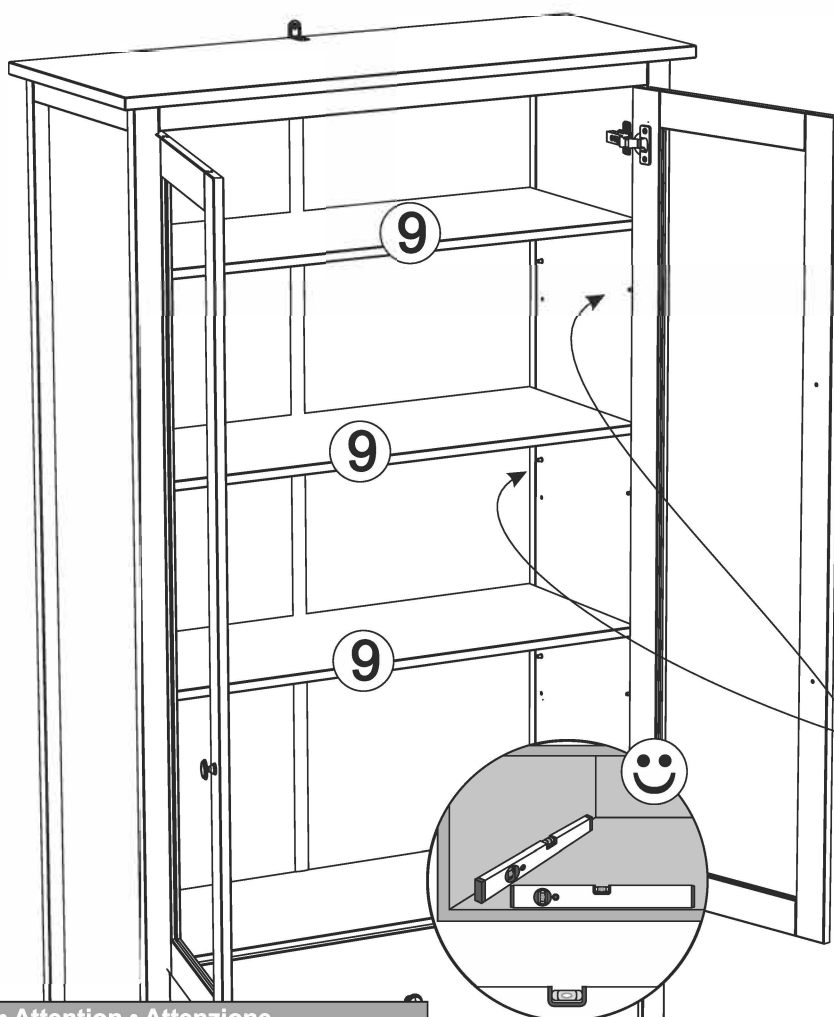

Q1 x 12

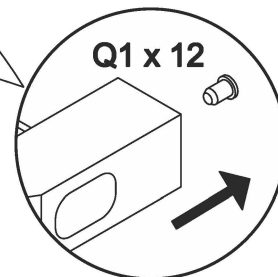

! Achtung • Attention • Attenzione Opgelet • Uwaga • Pozor • Figyelem Atenție • Dikkat • Внимание !	
(D)	Stellen Sie sicher, dass die Möbel eben sind, bevor Sie die Tür einstellen. Wenn die Möbel nicht geebnet sind, stehen die Türen und Schubladen schräg.
(GB)	Make sure the furniture is level before adjusting the door. If the furniture is not leveled, the doors and drawers will stand at an skew.
(FR)	Assurez-vous que les meubles sont de niveau avant de régler la porte. Si les meubles ne sont pas de niveau, les portes et les tiroirs se tiendront de travers.
(IT)	Assicurarsi che i mobili siano in piano prima di regolare la porta. Se i mobili non sono livellati, le ante e i cassetti saranno inclinati.
(NL)	Zorg ervoor dat het meubilair waterpas is voordat u de deur aanpast. Als het meubilair niet waterpas staat, staan de deuren en laden scheef.
(PL)	Przed wyregulowaniem drzwi upewnij się, że meble są wypoziomowane. Jeśli meble nie zostaną wypoziomowane, drzwi i szuflady staną pod kątem.
(CZ)	Před seřizením dveří se ujistěte, že je nábytek ve vodorovné poloze. Pokud nábytek není vyrovnán, budou dveře a zásuvky stát zkosené.
(SK)	Pred nastavením dverí sa uistite, že je nábytok vyrovnaný. Ak nábytok nebude vyrovnaný, dvere a zásuvky budú stát šikmo.
(HU)	Az ajtó beállítása előtt ellenőrizze, hogy a bútor vízszintesben van-e. Ha a bútor nincs kiegyenlítve, az ajtó és a fiókok ferdén állnak.
(RO)	Asigurați-vă că mobila este la nivel înainte de a regla ușa. În cazul în care mobilierul nu este nivelat, ușile și sertarele vor sta în picioare.
(TR)	Kapıyı ayarlamadan önce mobilyaların düz olduğundan emin olun. Mobilya düz değilse, kapılar ve çekmeceler eğik durur.
(RU)	Убедитесь, что мебель выровнена, прежде чем регулировать дверь. Если мебель не выровнена, двери и ящики будут стоять на перекосе.

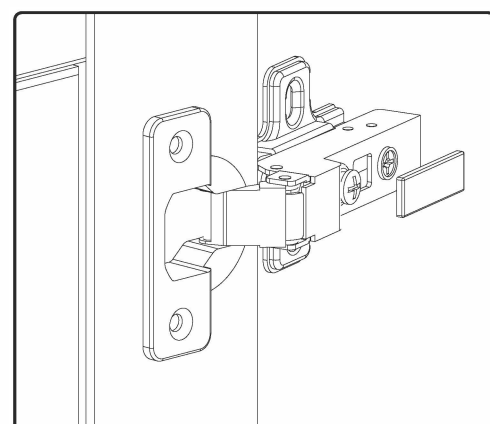
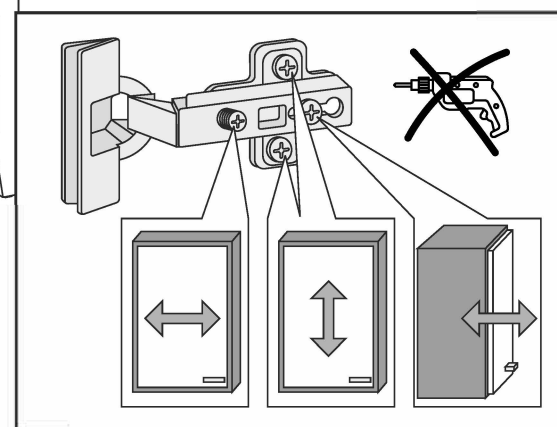

HOLZ LEBT - SO AUCH IHR MASSIVHOLZMÖBEL

DAS NATURPRODUKT HOLZ

Holz ist kein uniformer oder homogener Werkstoff - jeder Baum, jedes Stück Massivholz hat seine eigenen, unverwechselbaren Merkmale. Somit haben auch Möbel aus Massivholz besondere Ursprungszeichen. Charakteristisch für diesen naturgewachsenen Werkstoff sind Farb- und Strukturunterschiede, Verwachsungen, Unregelmäßigkeiten, Druckstellen, Äste, Harzgallen, Haar- und Kreuzrisse auch im Lack sowie Spannungen (Drehwuchs), die je nach Holzart und Wuchsgebiet unterschiedlich sind. Es sind Echtheitsmerkmale, die dem Holz erst die natürliche Schönheit verleihen und jedes Stück Möbel zu einem Unikat werden lassen.

Auf schwankende Raumtemperaturen und Luftfeuchtigkeit - auch jahreszeitbedingt - reagiert Holz, es „arbeitet“. Spannungen im Holz sowie ein Verziehen des Holzes sind daher nicht immer auszuschließen. Um die Stabilität zu verbessern, werden sogenannte Leimholzplatten als Basis für Massivholzmöbel genutzt. In einem aufwendigen Produktionsverfahren werden einzelnen Lamellen mit schadstofffreiem Leim an Kopf und/oder Seite zusammengesetzt. Diese Lamellen können in Breite und Länge innerhalb einer Platte unterschiedlich sein. Es ist handelsüblich, holzbedingte Fehler durch Einsetzen von Astspots und/oder Lamellos zu beseitigen.

Alle vorgenannten Merkmale sind ein Beweis des natürlichen Ursprungs und geben keinen Anlass zu Beanstandungen. Funktion, Gebrauch, Wert und Haltbarkeit dieser Möbel werden dadurch nicht beeinträchtigt.

EIGENSCHAFTEN VON HOLZ



&ste



Spannungen



Farbunterschiede



Quelle



Schwinden

FOLGENDES RAUMKLIMA IST OPTIMAL FÜR SIE UND IHR MASSIVHOLZMÖBEL:

Stabile Temperatur 18-23°C
Stabile Luftfeuchtigkeit von 45-55%
Kein direktes Sonnenlicht auf das Möbel

BESONDERHEITEN

Die Lebensgeschichte eines Baumes wird durch charakteristische Merkmale wie Zeichnung, Struktur und Farbe geprägt. Kein Baum gleicht dem anderen. Diese abweichenden Natur- und Wachstumsmerkmale machen aus jedem individuellen planbaren Echtholzmöbel in modellbezogener Material- und Verarbeitungsstruktur ein echtes Unikat mit einem einzigartigen Erscheinungsbild. Eine absolute Farb- und Strukturgleichheit, beispielsweise zwischen Planungsmuster und Lieferung, kann deshalb nicht garantiert werden. Diese Natur-Farbspiele sind eine warentypische Eigenschaft des gewachsenen Naturwerkstoffes und ein wesentliches, unverwechselbares Echtheitsmerkmal, kein Beanstandungsgrund.

LUFTFEUCHTIGKEIT

Holz ist ein natürlicher Werkstoff, der ständig Feuchtigkeit aufnimmt und wieder abgibt, je nach dem Feuchtigkeitsgehalt der lokalen Umgebung. Darum sollten Möbel keiner extrem großer oder zu niedriger Luftfeuchtigkeit ausgesetzt werden. Das Holz beginnt sonst wieder zu arbeiten, sich zu verziehen, offene Leimfugen oder Risse zu zeigen. Das Raumklima, das für Mensch und Pflanzen am besten ist (Medizin und Wissenschaft empfehlen Jahresdurchschnittswerte von 45-55% Luftfeuchtigkeit bei 18-23°C, kurzfristige Abweichungen von diesen Empfehlungen schaden nicht), ist auch für Kastenmöbel richtig.

LICHTEINWIRKUNG BEI MÖBELN

Starkes Kunst- und insbesondere Sonnenlicht verändern Oberflächen, besonders Holzoberflächen. Diese Art von „Sonnenbrand“ lässt Naturhölzer vergilben, gebeizte Hölzer ausbleichen. Schützen Sie Ihre wertvollen Möbel unbedingt vor extremer Lichteinwirkung, da eine 100-prozentige Lichtechtheit materialbedingt nicht zu erreichen ist. Das Sonnenlicht verändert alle Materialien! Besondere Vorsicht ist deshalb in hellen Südzimmern mit viel Glas geboten, dort sollten bei direkter Sonneneinstrahlung Vorhänge oder Jalousien geschlossen werden, da sonst eine Oberfläche schon nach wenigen Wochen an den beschienenen Stellen holzartbezogen heller oder dunkler werden kann.

FAZIT

Massives Holz ist ein „lebendiger“ Werkstoff, der sich bei starken Schwankungen von Temperatur und Luftfeuchtigkeit geringfügig ändern kann. Da für diese Möbel nur gut abgelagerte Hölzer verwendet werden, ist dieser Effekt auf ein Minimum begrenzt. Funktion und Gebrauchswert sind keinesfalls eingeschränkt. Extrem trockener Zentralheizungsluft und überhörter, sowie extrem nassen und niedrigen Zimmertemperaturen sollten Massivholzmöbel nicht ausgesetzt werden.