

# Schrank



Assembled size / Maße aufgebaut :

Height / Höhe : 2100 mm.

Width / Breite : 2307 mm.

Depth / Tiefe : 571 mm.

This unit can be assembled by two persons.

Aufbau mit zwei Personen.

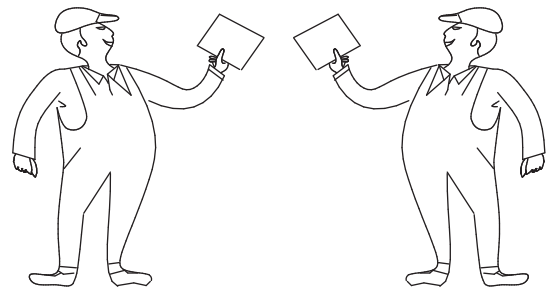

## Beachten Sie bitte:

Massiv-Holz ist ein organisches Material und passt sich den jeweiligen Umweltbedingungen an. Leichter Verzug, Haarrisse und Oberflächendetails sind daher kein Reklamationsgrund, sondern ein Qualitätsmerkmal des Materials.

The necessary tools  
(not included)

Die dazu benötigten Werkzeuge  
(ausschliesslich)

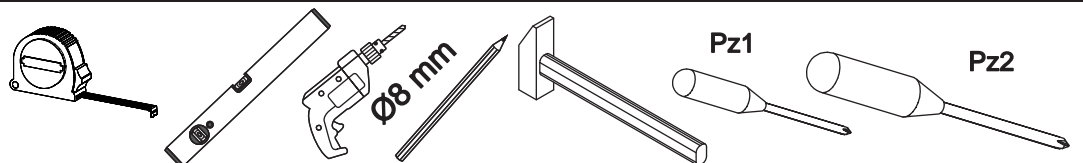

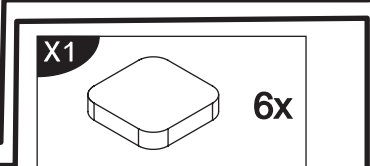
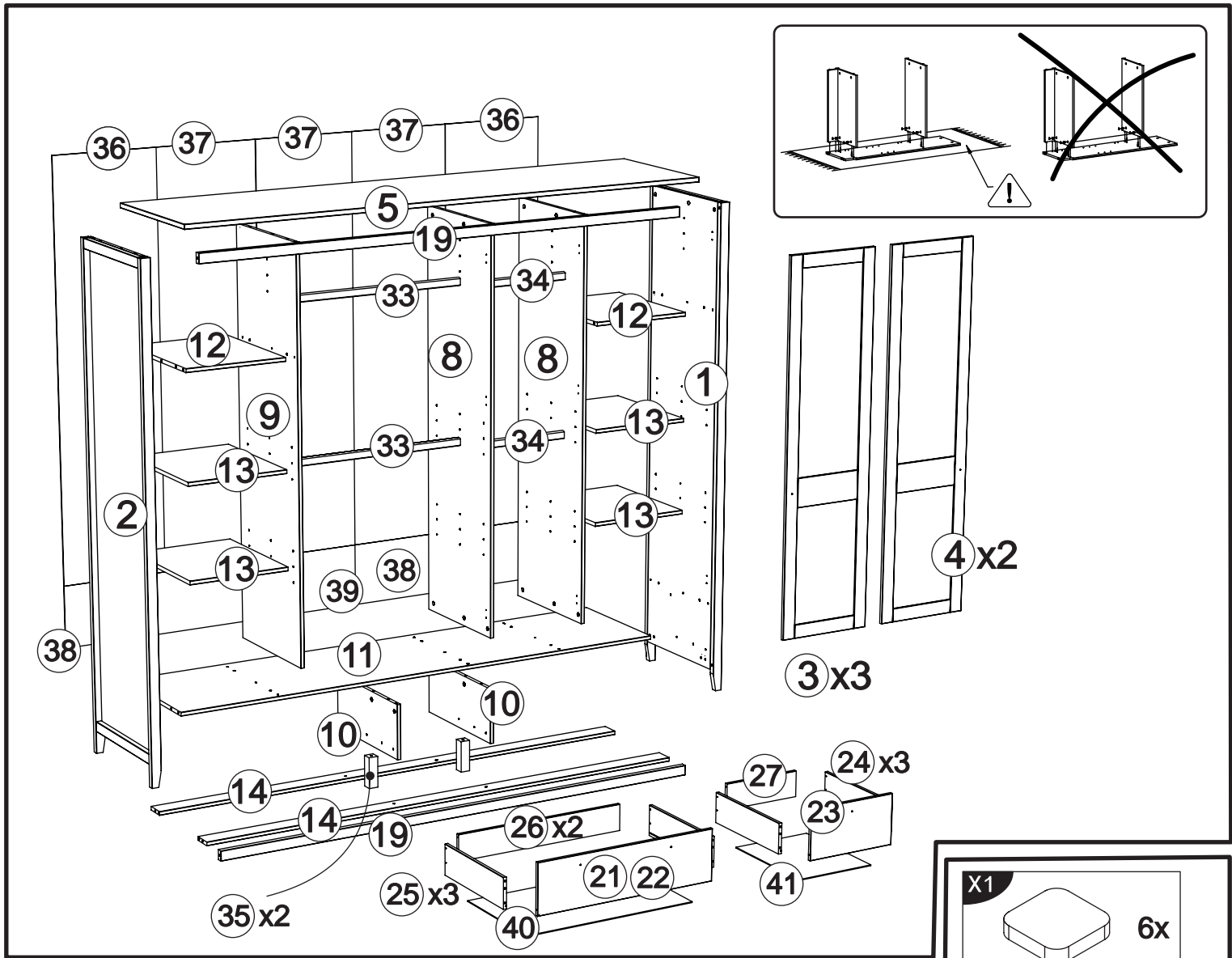

|  |                                   |  |                                 |                                  |
|--|-----------------------------------|--|---------------------------------|----------------------------------|
| <b>B1</b><br><br>42x<br>Ø8x35          | <b>B3</b><br><br>2x<br>Ø8x40      | <b>B15</b><br><br>2x<br>Ø8x60              | <b>C1</b><br><br>58x<br>34 mm   | <b>C10</b><br><br>3x<br>34/16/34 |
| <b>D1</b><br><br>64x<br>Ø15x12         | <b>D3</b><br><br>36x<br>Ø17       | <b>E1</b><br><br>8x<br>Ø3x15               | <b>E2</b><br><br>26x<br>Ø3x20   | <b>E5</b><br><br>12x<br>Ø3x30    |
| <b>F2</b><br><br>74x<br>Ø3.5x15        | <b>G16</b><br><br>2x<br>Ø4.5x55   | <b>K8</b><br><br>2x<br>Ø3.5x15             | <b>O19</b><br><br>18x<br>Ø6.3x9 | <b>M3</b><br><br>4x<br>Ø7x50     |
| <b>V25</b><br><br>6x<br>Ø35 IE S       | <b>V26</b><br><br>9x<br>Ø35 P S   | <b>S17</b><br><br>3x<br>GCHX<br>GTV 500 mm | <b>R7</b><br><br>10x            | <b>J2</b><br><br>10x<br>M4x22    |
| <b>Q10</b><br><br>1x                   | <b>H5</b><br><br>26x              | <b>Q1</b><br><br>16x                       | <b>U5</b><br><br>8x             | <b>Z1</b><br><br>1x<br>SW4       |
| <b>H2</b><br><br>5 mm<br>1x<br>1698 mm | <b>F11</b><br><br>75x<br>Ø3.5x17M | <b>L1</b><br><br>3x                        | <b>B10</b><br><br>2x<br>Ø8x40   | <b>L15</b><br><br>5x<br>40x30x20 |

**1** B1 x 24 D1 x 28

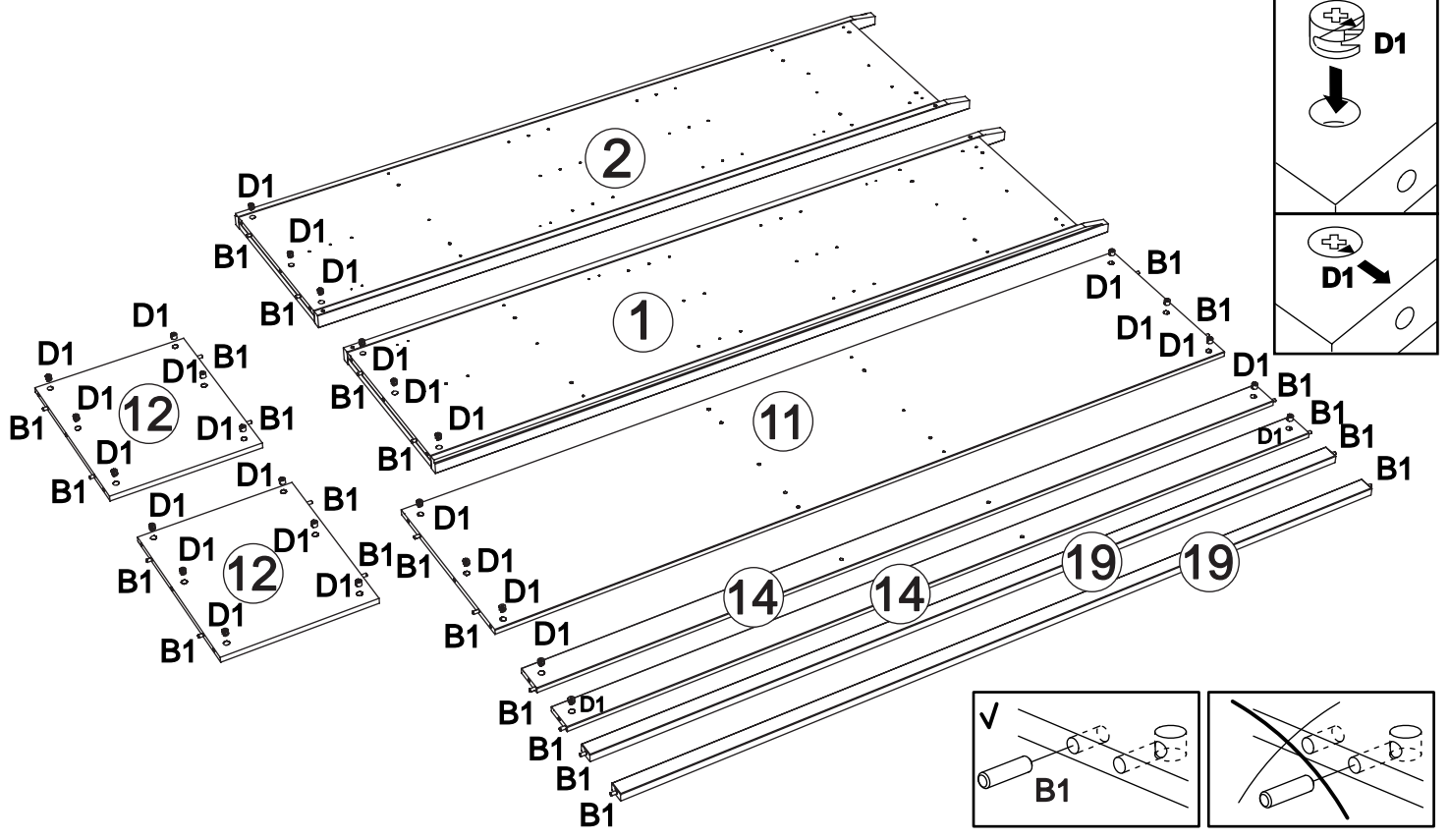

**2** B1 x 12 B15 x 2 D1 x 24

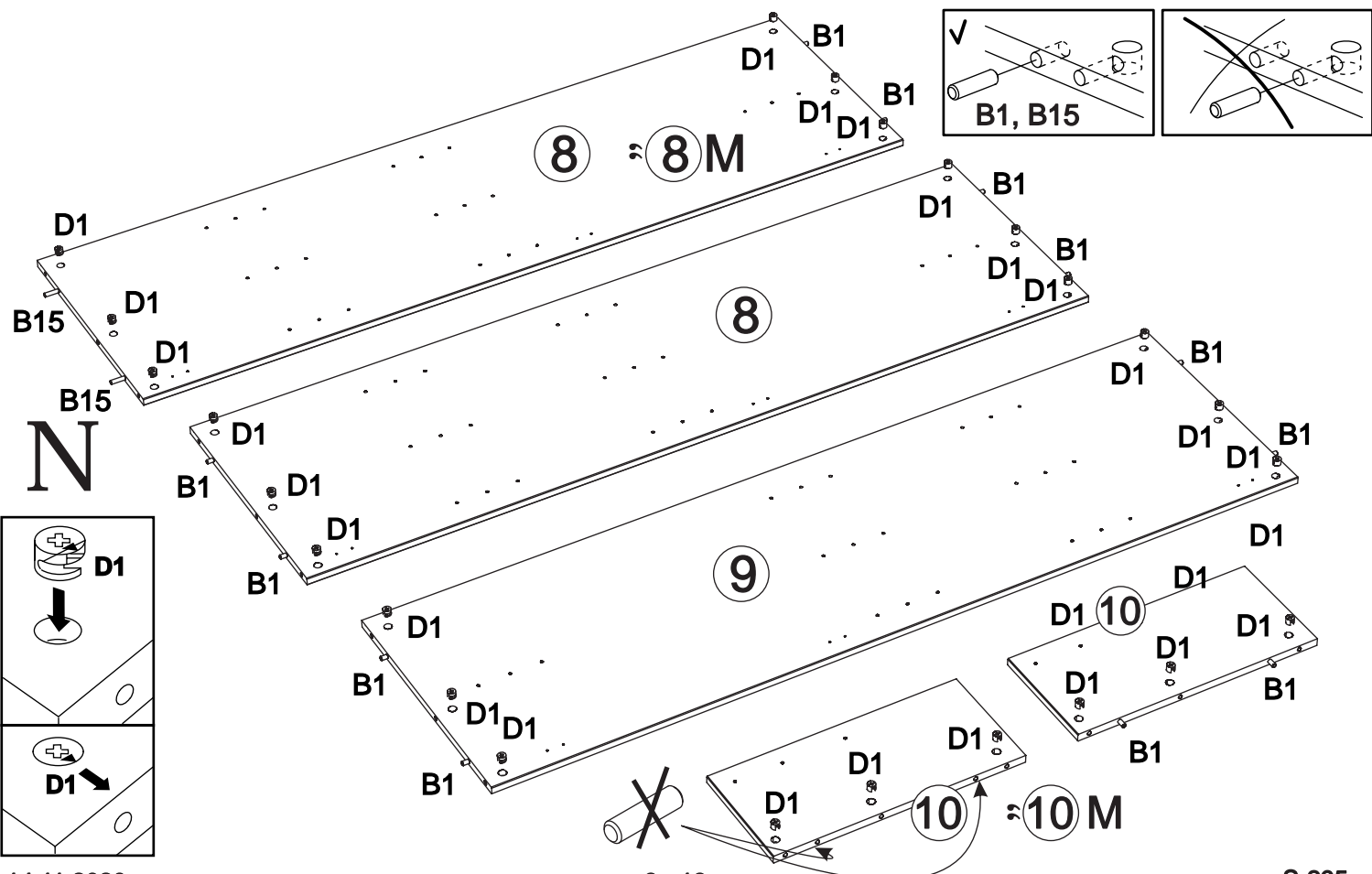

3

C1 x 22

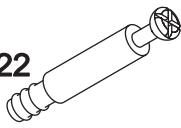

PZ2

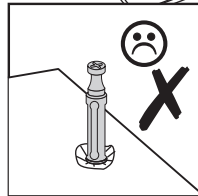
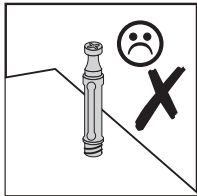
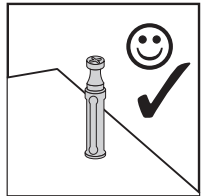
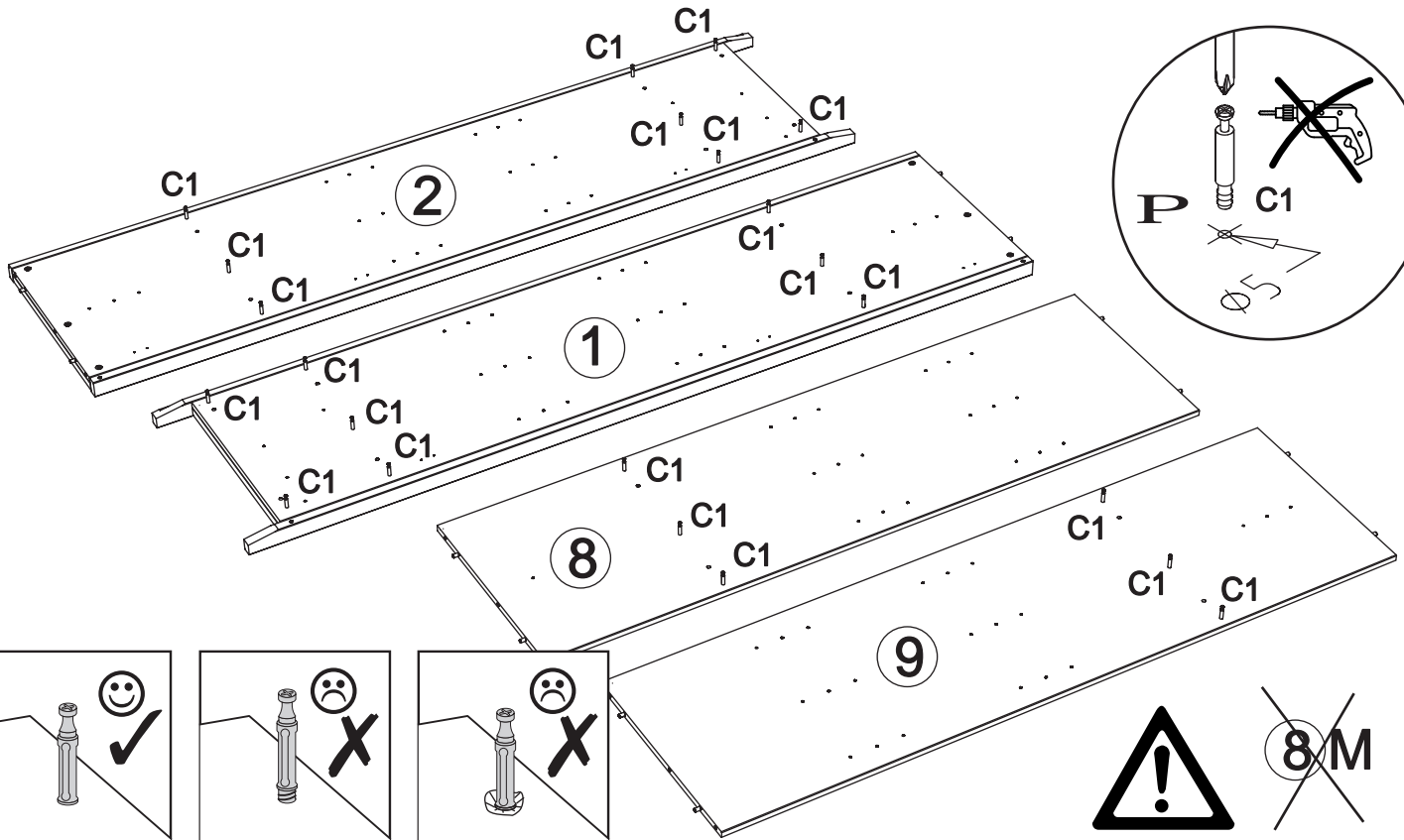

4

C1 x 21

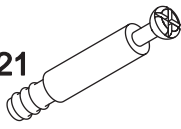

PZ2

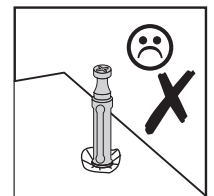
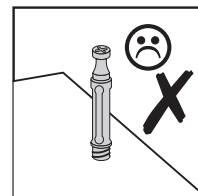
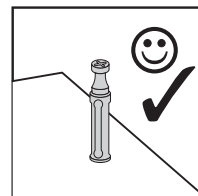
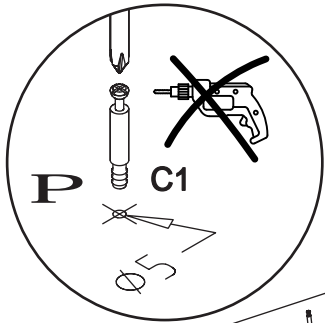
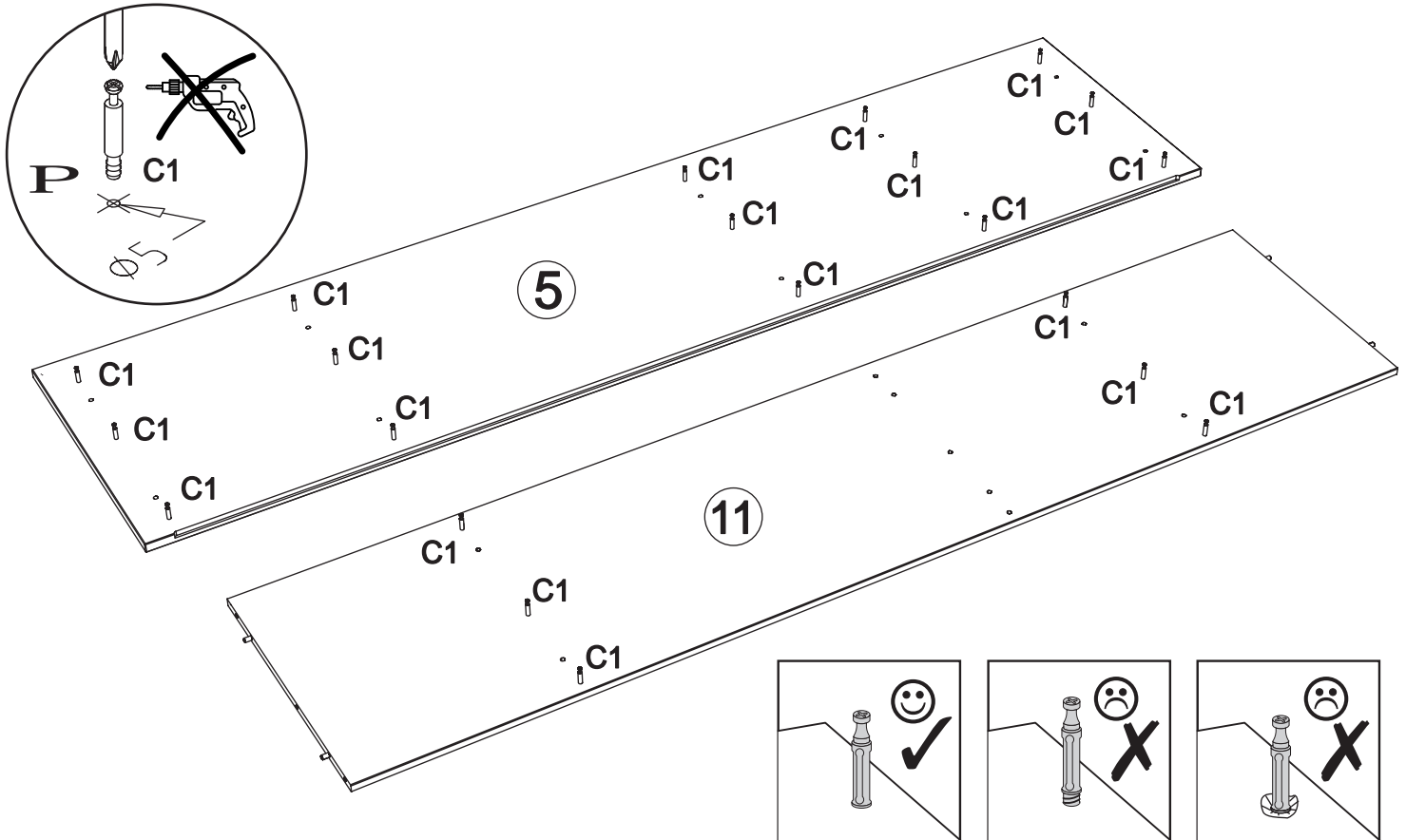

5

C1 x 3

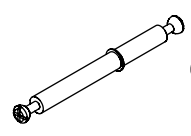

C1 x 3

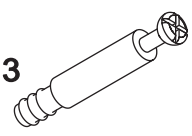

PZ2

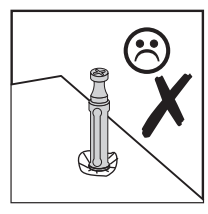
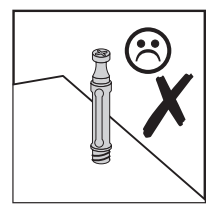
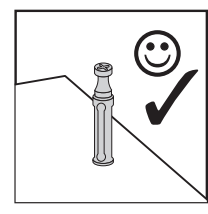
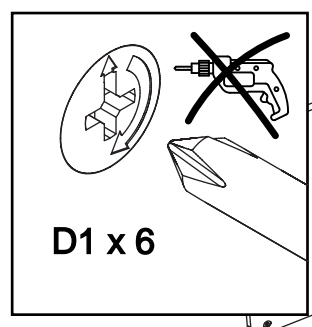
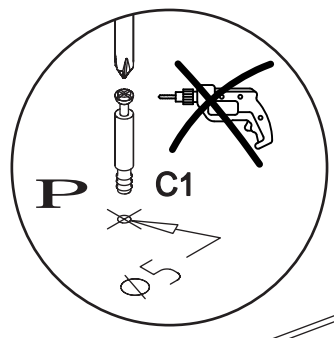
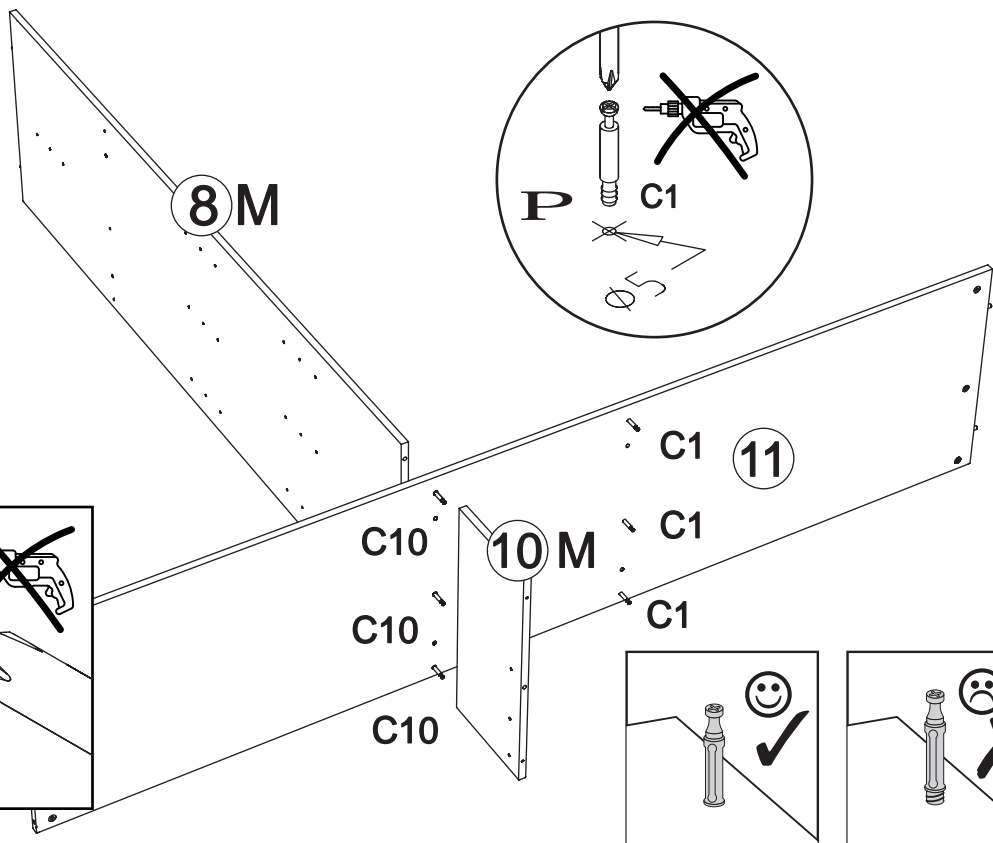

6



PZ2

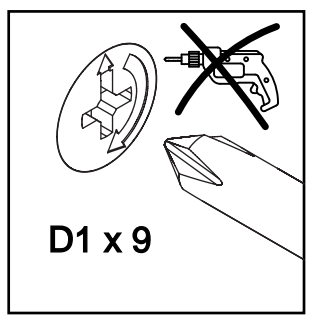
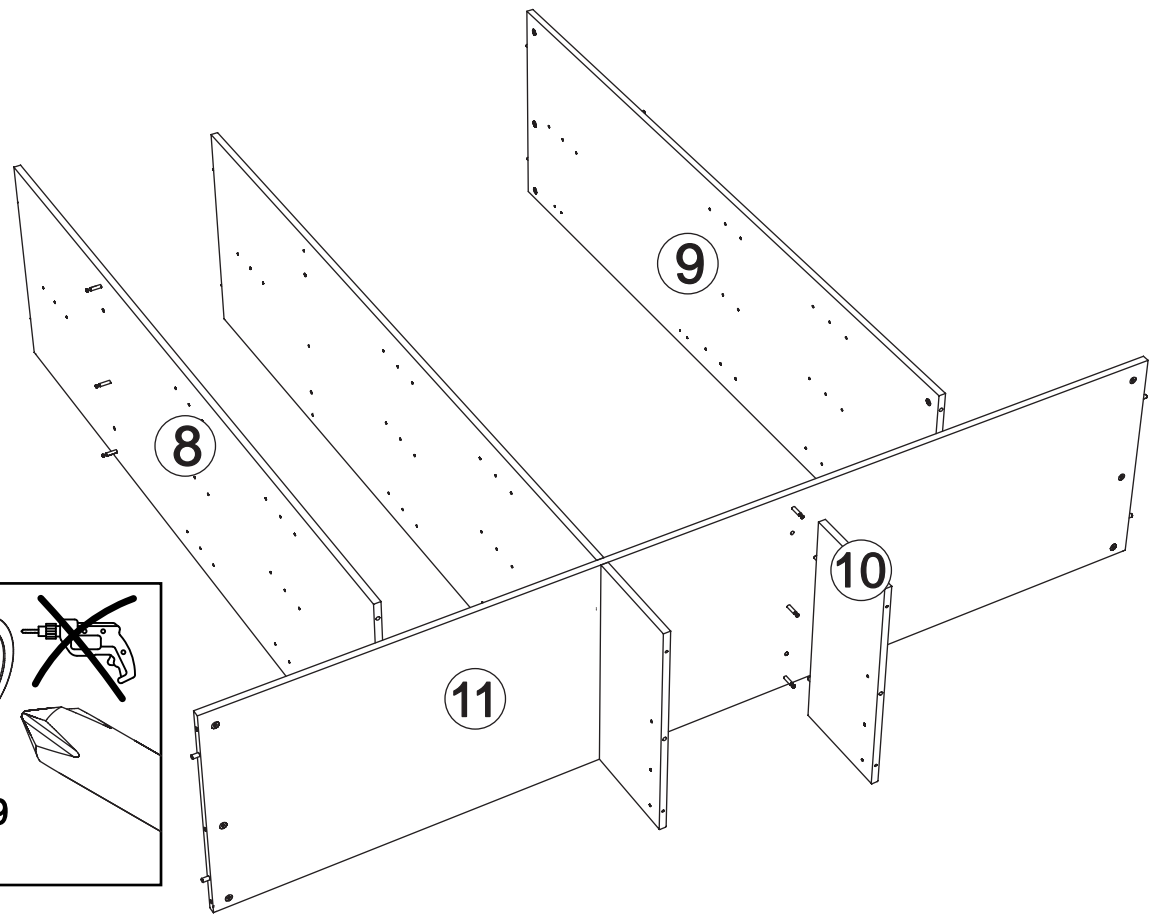

7

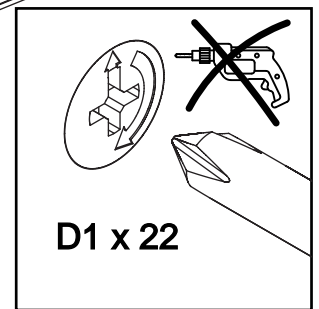
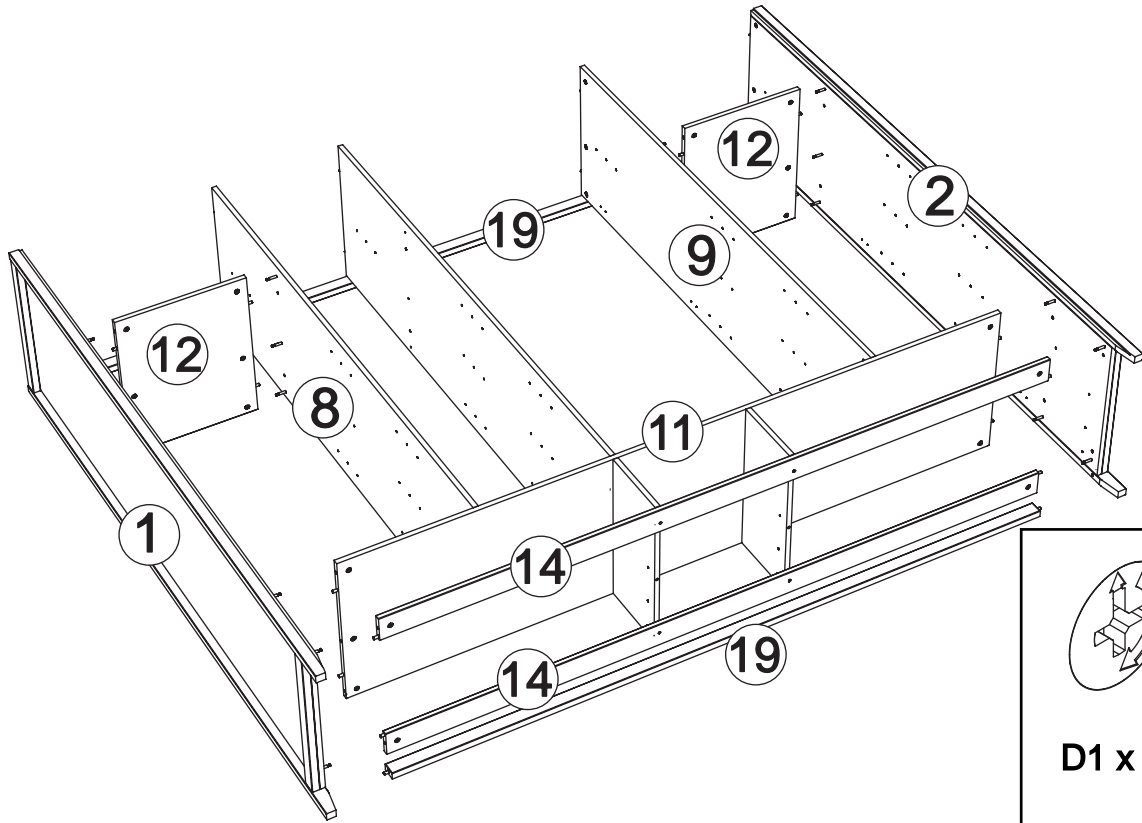
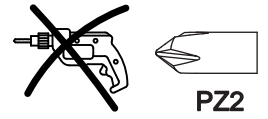

8

M3 x 4

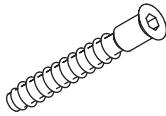

Z1 x 1

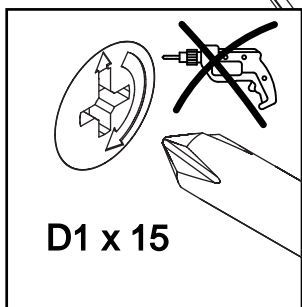
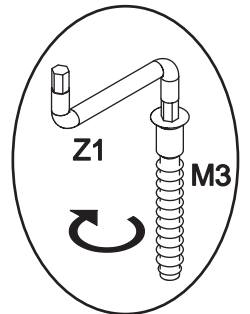
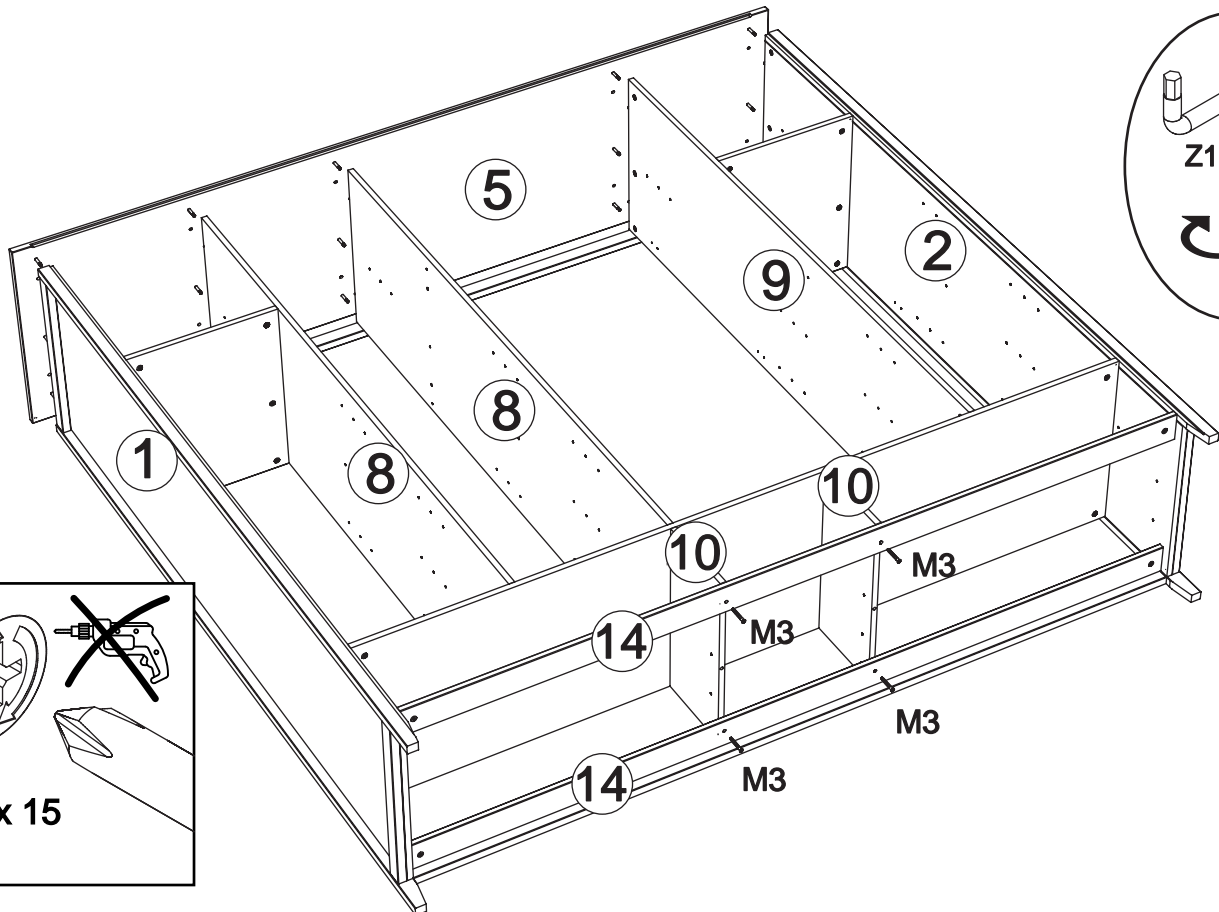
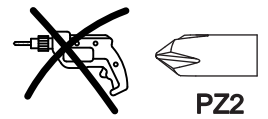
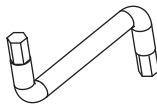

9

F2 x 12

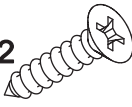

L1 x 3

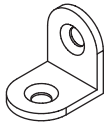

L15 x 3



PZ2

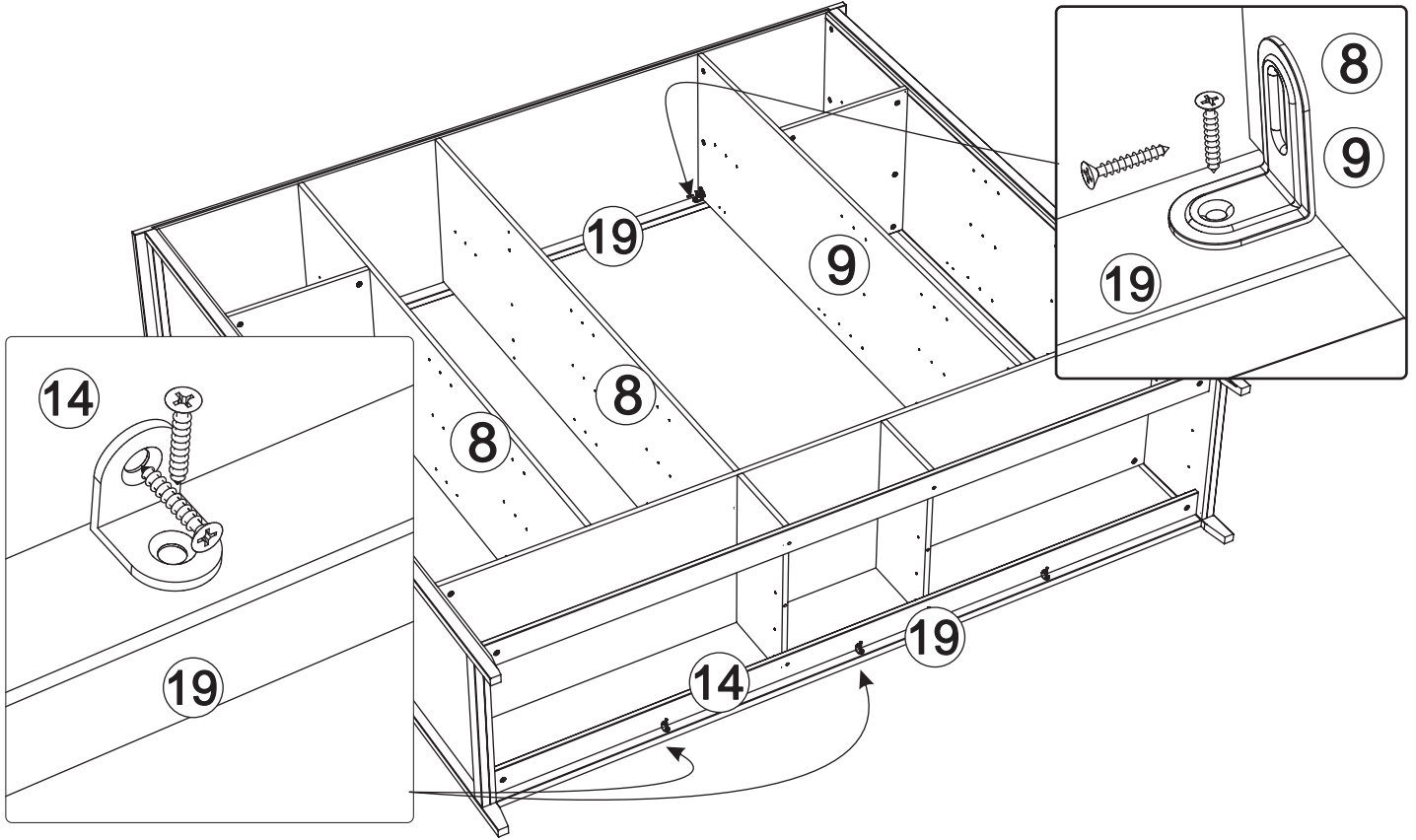

10

B3 x 2

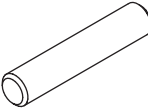

K8 x 2

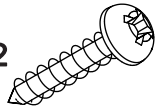

Q10 x 1

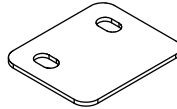

PZ2

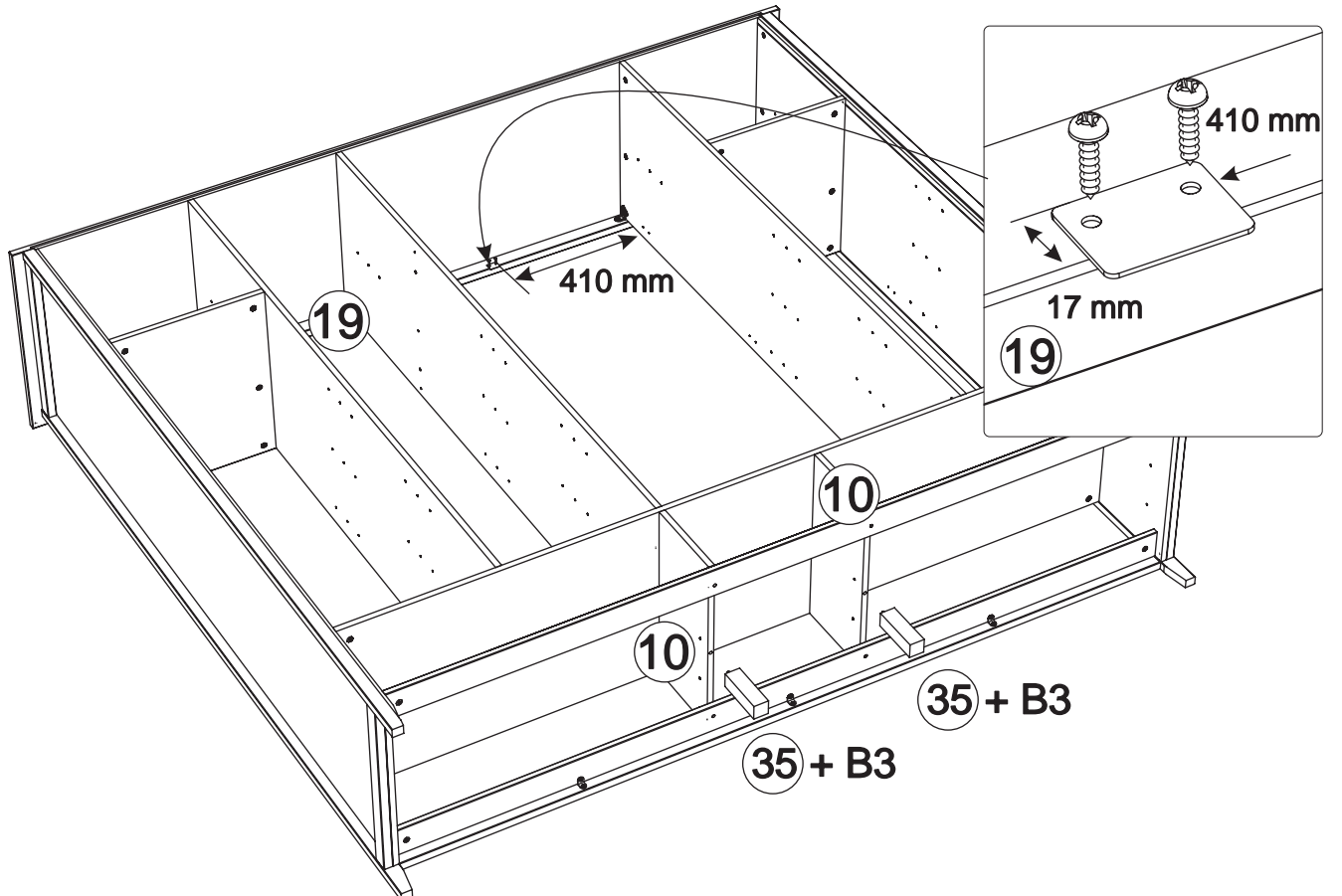

11

F11 x 64

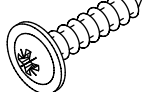

E2 x 26

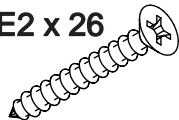

H5 x 26



H2 x 1

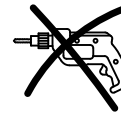
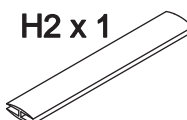

PZ1



X = Y

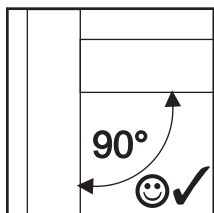
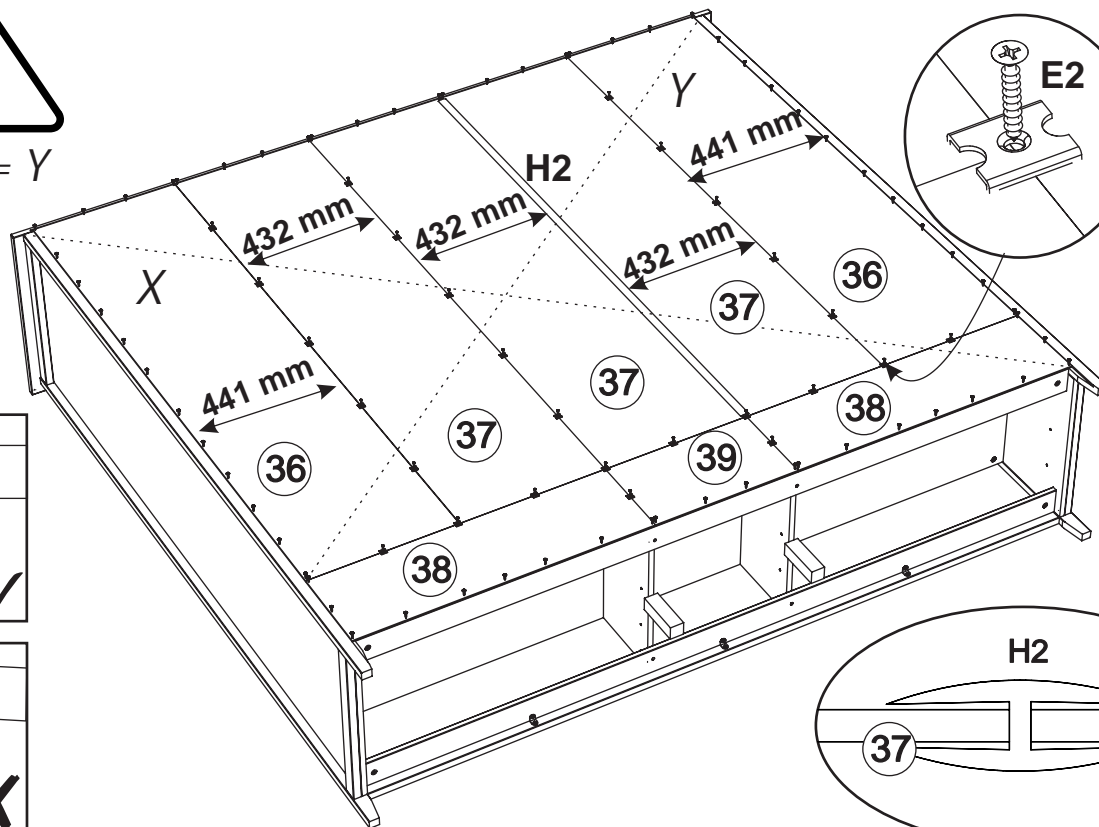

90°

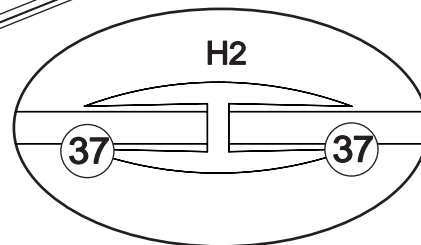
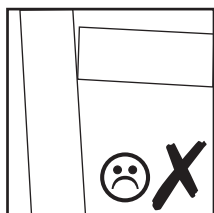

H2

37

37

12

X1 x 6

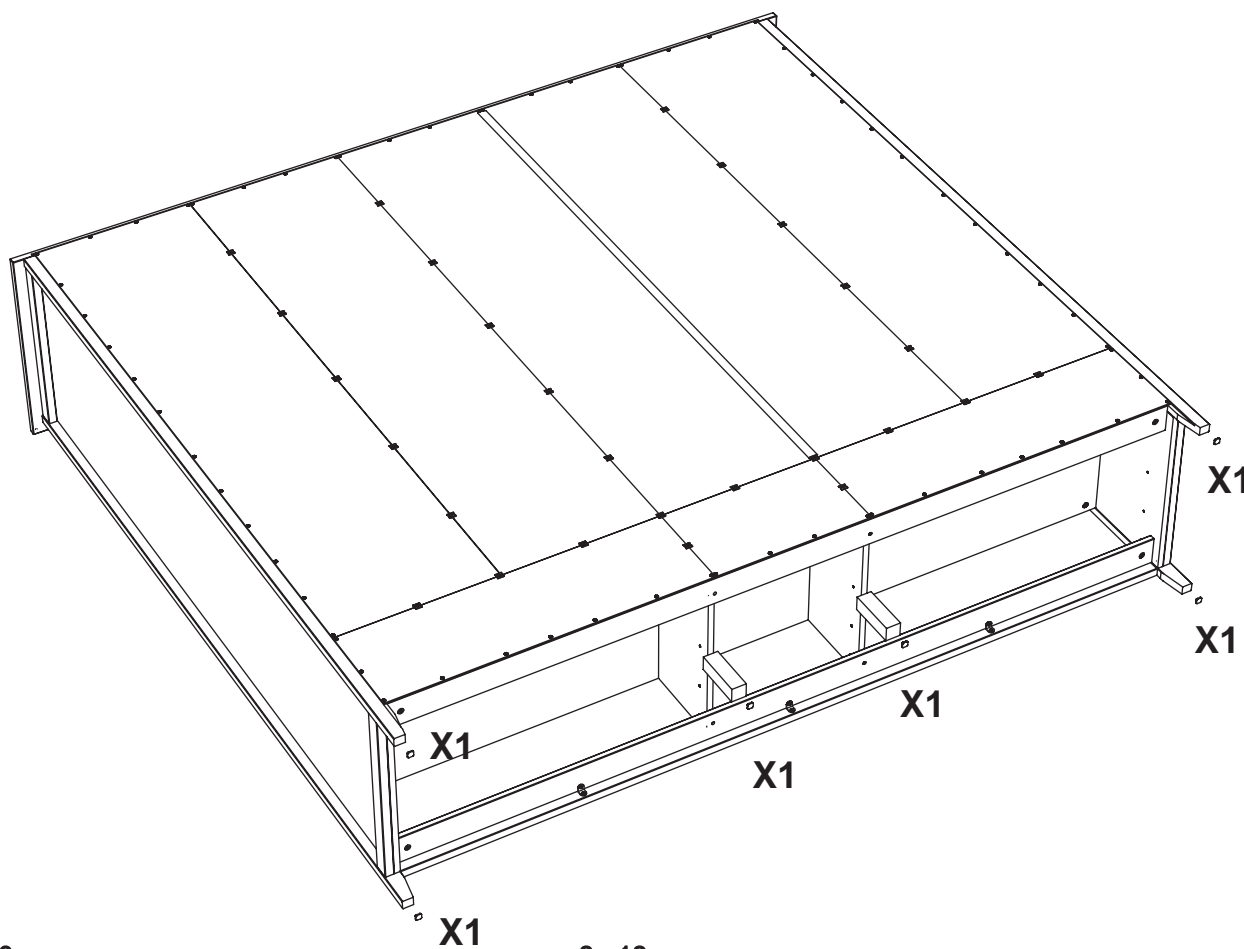
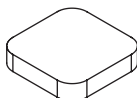



**NB !!!**

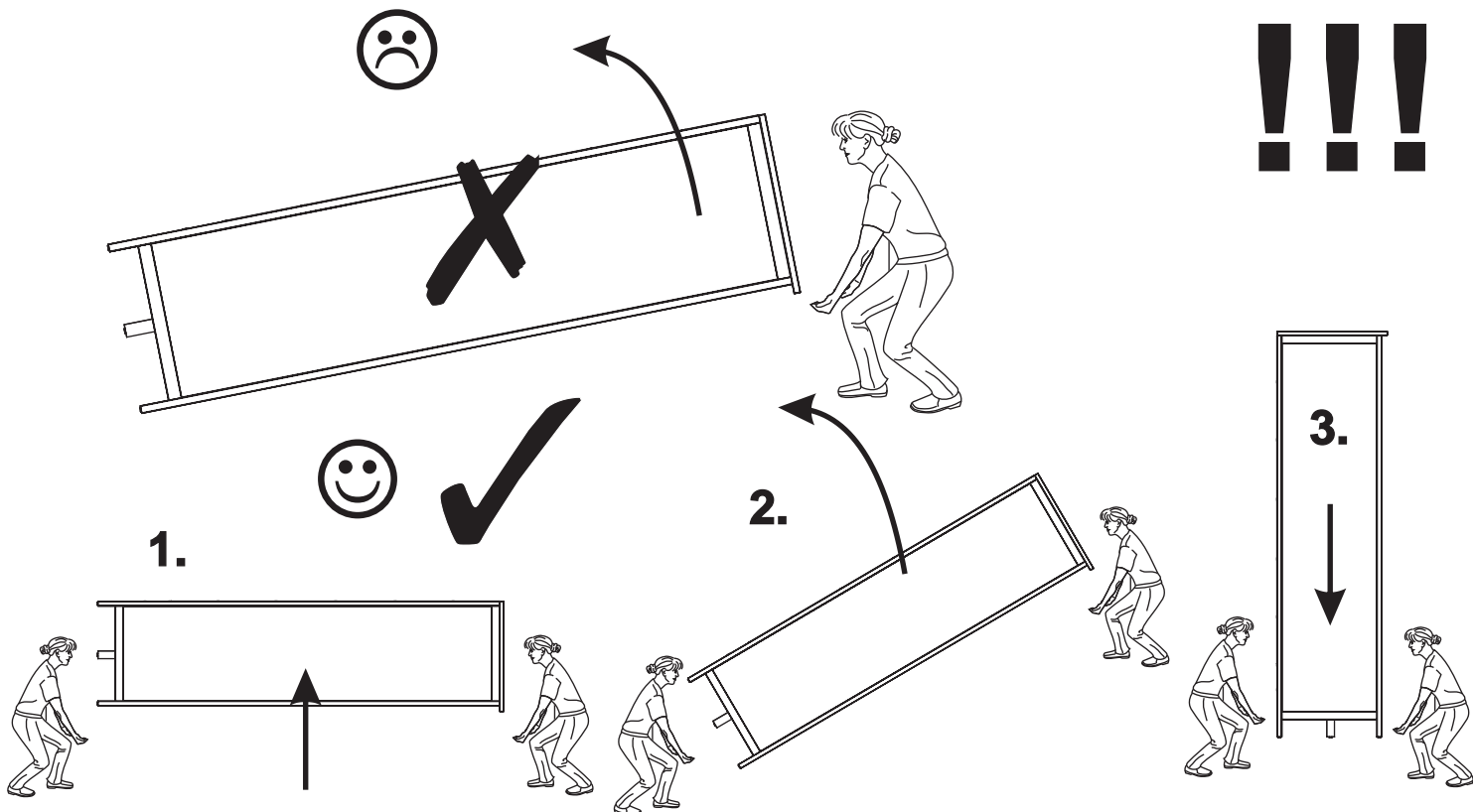

**NB !!!**

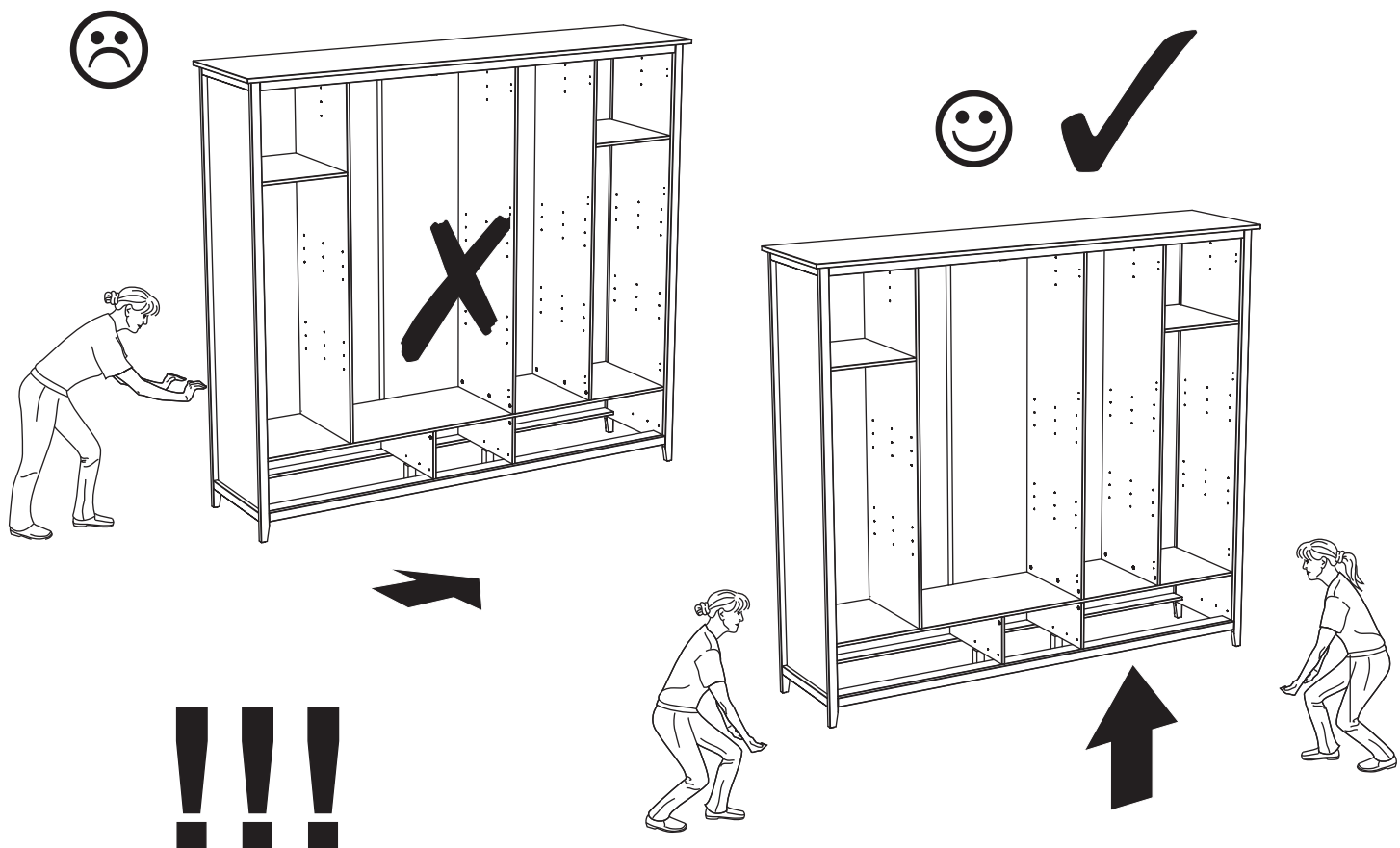

13

F2 x 2

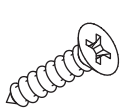

G16 x 2

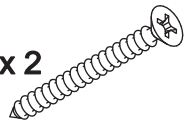

B10 x 2

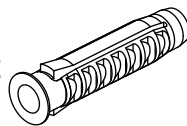

L15 x 2

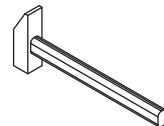

PZ2

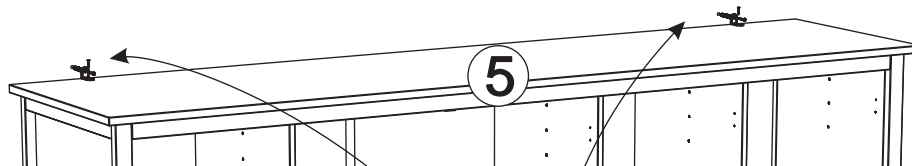

| Achtung • Attention • Attenzione<br>Opgelet • Uwaga • Pozor • Figyelem<br>Aten ie • Dikkat |  |
|--|--|
| (D)  | Stellen Sie vor dem Anbringen der Möbel an der Wand sicher, dass sie eben sind. Wenn die Möbel nicht geebnet sind stehen die Türen und Schubladen schräg.          |
| (GB)   | Before attaching the furniture to the wall, make sure it is leveled. If the furniture is not leveled, the doors and drawers will stand at an skew.                 |
| (FR)   | Avant de fixer le meuble au mur, assurez-vous qu'il est de niveau. Si les meubles ne sont pas de niveau, les portes et les tiroirs se tiendront en biais.          |
| (IT)   | Prima di fissare i mobili alla parete, assicurarsi che siano livellati. Se i mobili non sono livellati, le ante e i cassetti saranno inclinati.                    |
| (NL)   | Voordat u het meubilair aan de muur bevestigt, moet u ervoor zorgen dat het waterpas staat. Als het meubilair niet waterpas staat staan de deuren en laden schief. |
| (PL)   | Przed przymocowaniem mebli do ściany upewnij się, że jest wy poziomowany. Je li meble nie zostaną wy poziomowane, drzwi i szuflady stan ą pod kątem.               |
| (CZ)   | Před p ípevn ěním nábytku ke zdi se ujist ěte, že je vyrovnan ě. Pokud není nábytek vyrovnan ě, budou dve re a zásuvky stát zkosen ě.                              |
| (SK)   | Pred prípevnením nábytku na stenu sa uistite, že je vyrovnan ý. Ak nábytok nebude vyrovnan ý, dvere a zásuvky budú st á ťiĥmo.                                     |
| (HU)   | Miel tt a bútorokat a falhoz rögzít i, ellen rizze, hogy azok el vannak-e állítva. Ha a bútor nincs kiegyenlít ve, az ajtók és a fiókok ferdén állnak.             |
| (RO)   | Înainte de a fixa mobilierul pe perete, asigură-te că acesta este nivelat. În cazul în care mobilierul nu este nivelat, u ile i sertarele vor sta în picioare.     |
| (TR)   | Mobilyaları duvara ba lamadan önce, düz oldu undan emin olun. Mobilya düz de ilse, kapılar ve çekmeceler e ik durur.   |
| (RU)   |  |

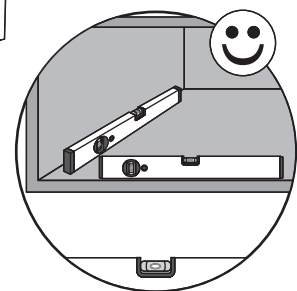
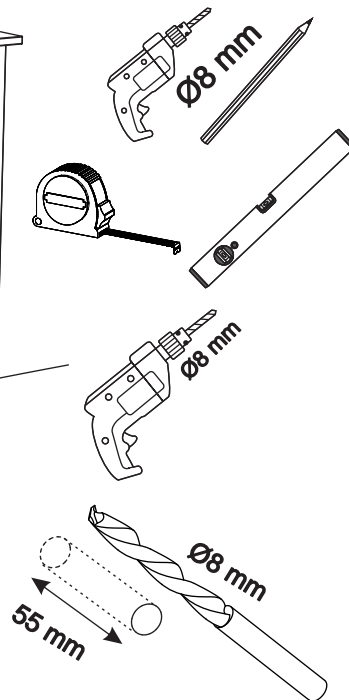
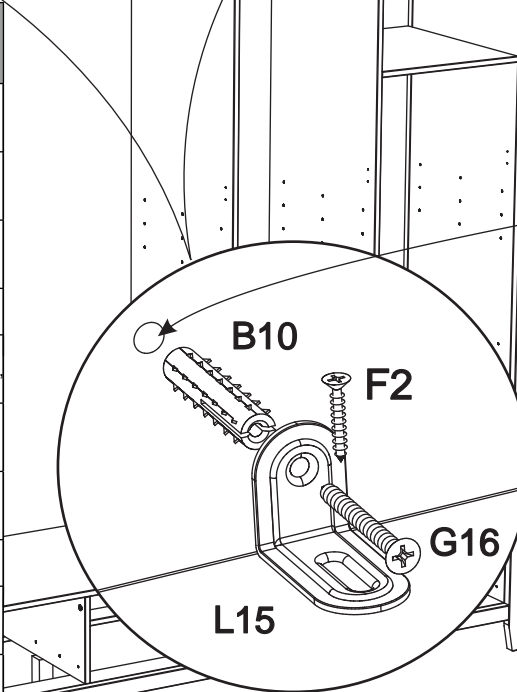

| Achtung • Attention • Attenzione<br>Opgelet • Uwaga • Pozor • Figyelem<br>Aten ie • Dikkat |   |
|--|---|
| (D)  | Wandbefestigung dient als Kippschutz – unbedingt anbringen! Bei einigen Wandtypen kann ein Spezialdübel erforderlich sein!  |
| (GB)   | The wall fastening serves to prevent tipping – be absolutely sure to mount it! For certain wall types, a special wall plug may be necessary!                                      |
| (FR)   | La fixation murale sert de protection contre le basculement – à installer impérativement ! Pour certains types de murs il faut des chevilles spéciales !                          |
| (IT)   | Il fissaggio alla parete serve da protezione anti-ribaltamento – attaccarla assolutamente! Per alcune strutture di parete può essere necessario un tassello speciale!             |
| (NL)   | Bevestiging aan de muur dient als kantelbescherming – zeker en vast bevestigen! Bij enkele muurtypen is een speciale plug misschien vereist!                                      |
| (PL)   | Mocowanie do ściany jest jednocześnie nie zabezpieczeniem przed przewróceniem – koniecznie zamontowa ! Do niektórych rodzajów cian koniecznie zastosowa specjalne kołki mocujące. |
| (CZ)   | Montáž na st ěnu slouží jako ochrana proti p evrhnut ě – bezpodměn ě n umíst ěte! U n ěkterých typ ů st ěn m ěže být zapotřebí speciální hmoždinka!                               |
| (SK)   | Upevnenie na stenu slúži ako ochrana proti prevráteniu – bezpodmienen e použite! Pre niektoré druhy stien môže by potrebná speciálna hmoždinka!                                   |
| (HU)   | A termékét a falhoz rögzít i, különben az felborulhat! Egyes faltípusoknál speciális tiplít kell használni!   |
| (RO)   | Sistemul de fixare la perete serve te ca protec ie la r sturnare – de montat obligatoriu! Pentru unele tipuri de pere i este posibil s fie necesar un diblu special!              |
| (TR)   | Duvardaki sabitleme, devrilmeye kar ı bir emniyet tedbiridir ve mutlaka monte edilmelidir! Bazı duvar tiplerinde bunun için özel bir dübel gerekli olabilir!                      |
| (RU)   |   |

|    |  |
|----|--|
| D  | Das beigefügte Wandbefestigungsmaterial (Dübel und Schrauben) eignet sich nur für festes Mauerwerk (z.B. Beton- oder Ziegelwände). Für andere Wandaufbauten sind eventuell Spezialdübel und andere Schrauben notwendig. Ziehen Sie gegebenenfalls eine Fachkraft zurate.                                     |
| GB | The enclosed wall mounting materials (dowels and screws) are only suitable for solid masonry (e. g. concrete or brick walls). Special dowels and other screws may be necessary for other wall constructions. If necessary, please consult a qualified professional.  |
| FR | Le matériel de fixation murale fourni (chevilles et vis) convient uniquement à des murs solides (p. ex. murs en béton ou en briques). Pour les autres constructions de murs, il faut éventuellement des chevilles spéciales et d'autres vis. Faites-vous conseiller par un spécialiste.                      |
| IT | I materiali di fissaggio allegati (tasselli e viti) sono adatti solo ai muri compatti (ad es. di calcestruzzo o mattoni). Per altri tipi di pareti è probabile che occorrano tasselli speciali e altre tipologie di viti. Richiedere eventualmente il consiglio di un esperto.                               |
| NL | Het bijgeleverde bevestigingsmateriaal (pluggen en schroeven) is geschikt voor vaste muren (bijv. betonnen of bakstenen muren). Voor andere muurconstructies zijn eventueel speciale pluggen en andere schroeven noodzakelijk. Consulteer eventueel een vakman.  |
| PL | Załączony zestaw montażowy (kołki i śruby) jest przeznaczony do mocowania artykułów do ścian wykonanych z cegły lub betonu. Przy montażu artykułu na cianie wykonanej z innych materiałów, należy zastosować odpowiednie do niej zamocowanie. W razie wątpliwości prosimy zasięgnąć porady fachowca.         |
| CZ | Příložený materiál pro montáž na st ěnu (hmoždinky a šrouby) je vhodný jen pro pevné zdivo (např. betonové nebo cihlové st ěny). Pro jiné skladby st ěn budou p ípadn ě nutné speciální hmoždinky a jiné šrouby. Pora de se p ípadn ě s odborníkem.  |
| SK | Priložený materiál pre upevnenie na stenu (hmoždinky a skrutky) je vhodný len pre pevné murivo (napr. betónové alebo tehlové steny). Pre iné steny sú potrebné príp. špeciálne hmoždinky a iné skrutky. V prípade potreby sa pora de s odborníkom.   |
| HU | A mellékelt fal rögzít i készlet (tiplé és csavarok) csak tömött falazatban (pl. betonfalban, téglafalban) használható. Más faltípusokhoz speciális tiplire és csavarra lesz szükség. Szükség esetén kérje ki egy szakember véleményét.  |
| RO | Materialul furnizat pentru montajul de perete (dibluri i uruburi) este adecvat numai pentru zid rie solid (de exemplu pere i din beton sau din c r mid ). Pentru alte structuri de pere i, este posibil s fie necesare dibluri speciale, precum i alte uruburi. Dacă este necesar, consulta i un specialist. |
| TR | Teslimat kapsamındaki duvar tipi sabitleme materyali (dübel ve vidalar) sadece beton ve tu la duvarlar gibi sa lam duvar yapılar için uygundur. Ba ka duvar yapılar için özel dübeller veya ba ka vidalar gerekli olabilir. Gerekirse bir uzmandan yardım alın.  |
| RU |  |

14

O19 x 18

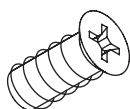

S17 x 3

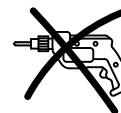
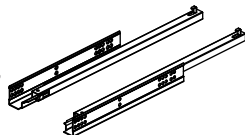

PZ2

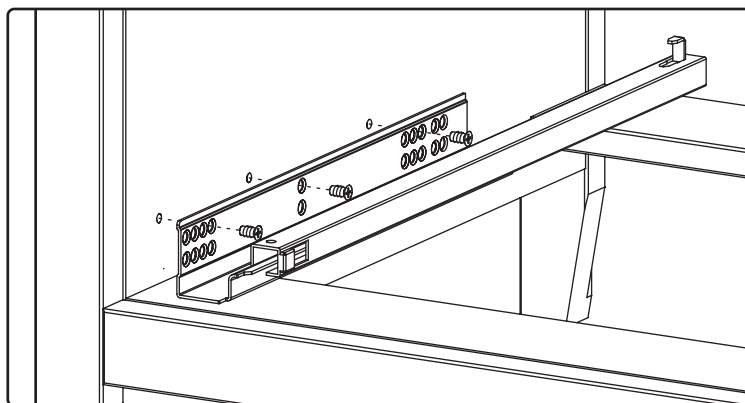
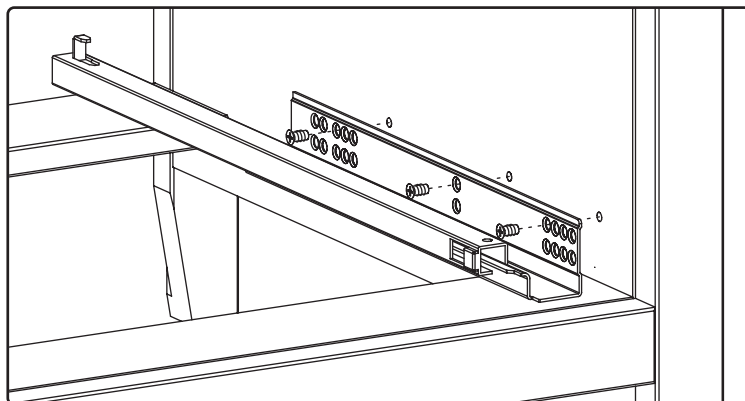
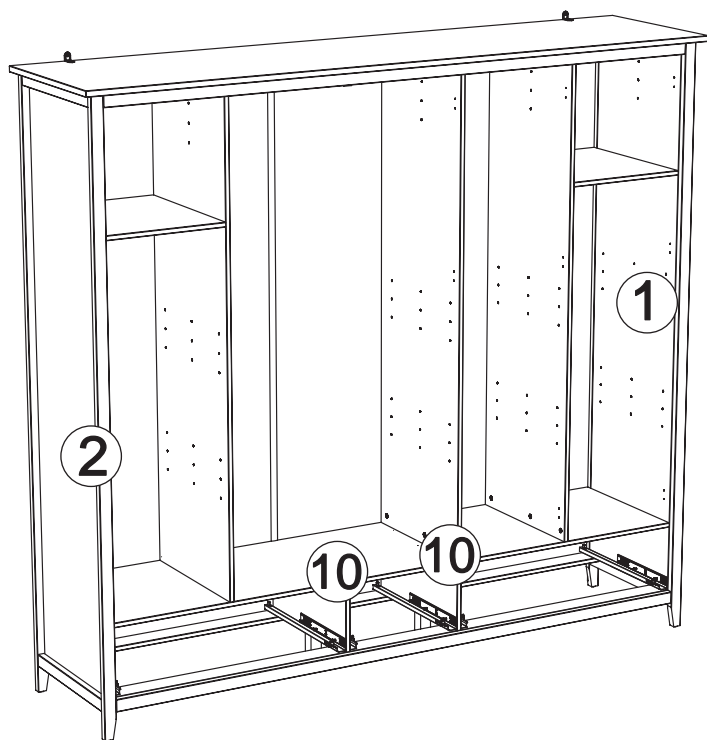

15

F2 x 30

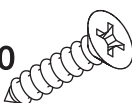

V25 x 6

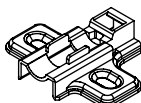

V26 x 9

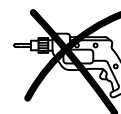
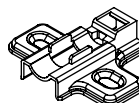

PZ2

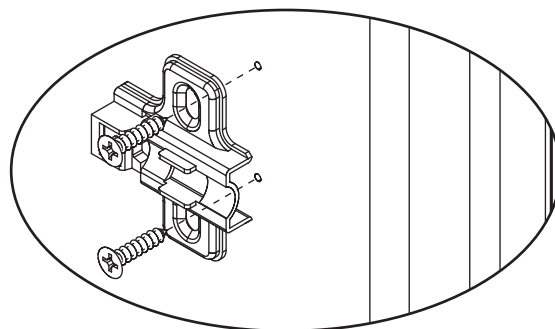
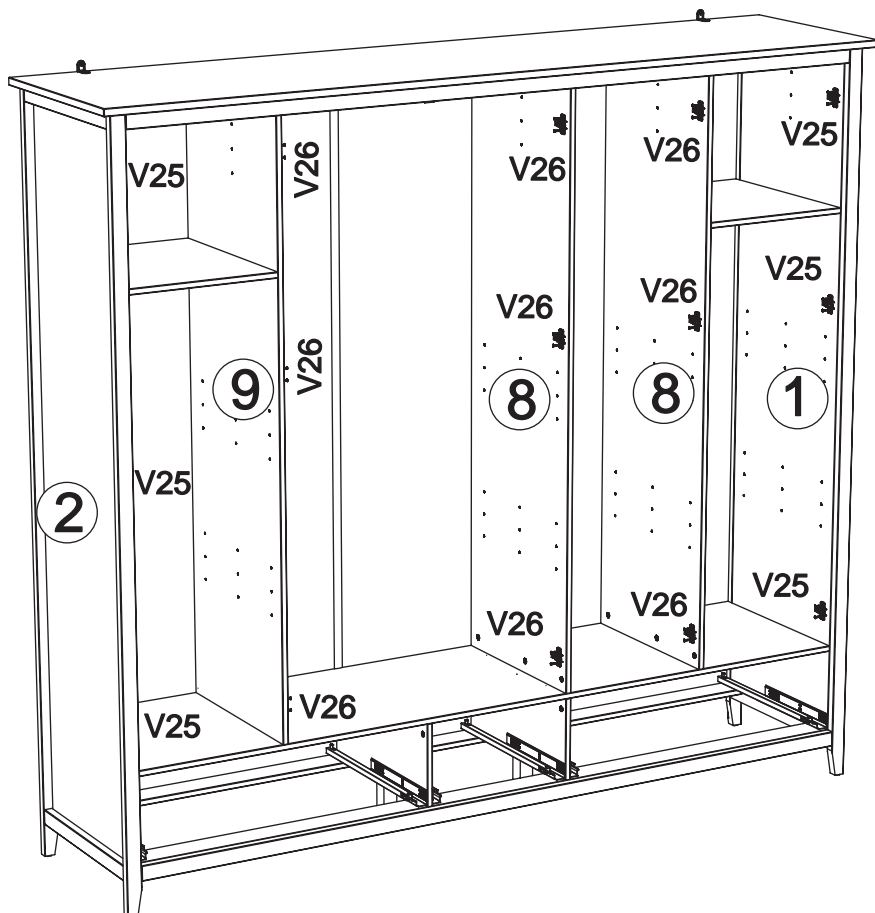

15

E1 x 8

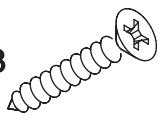

U5 x 8

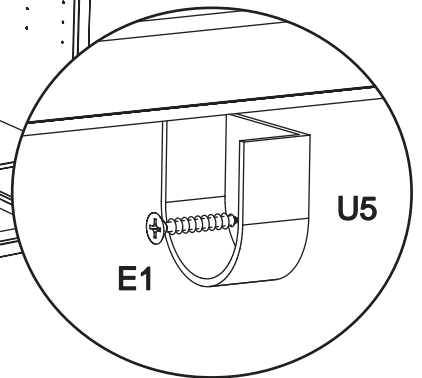
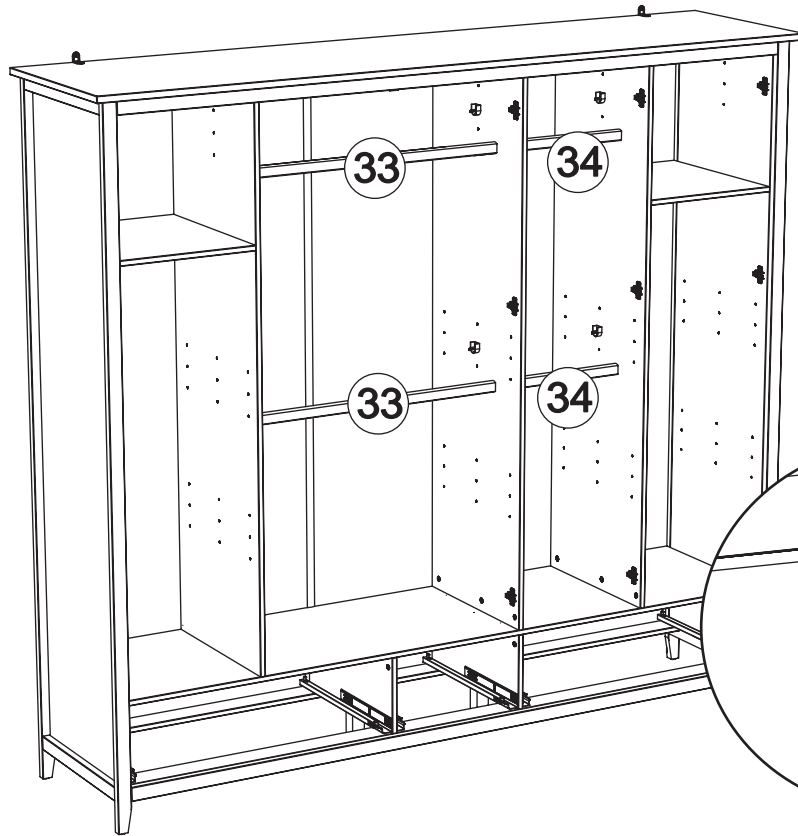
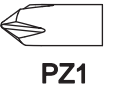

16

B1 x 6

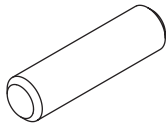

D1 x 12



C1 x 12

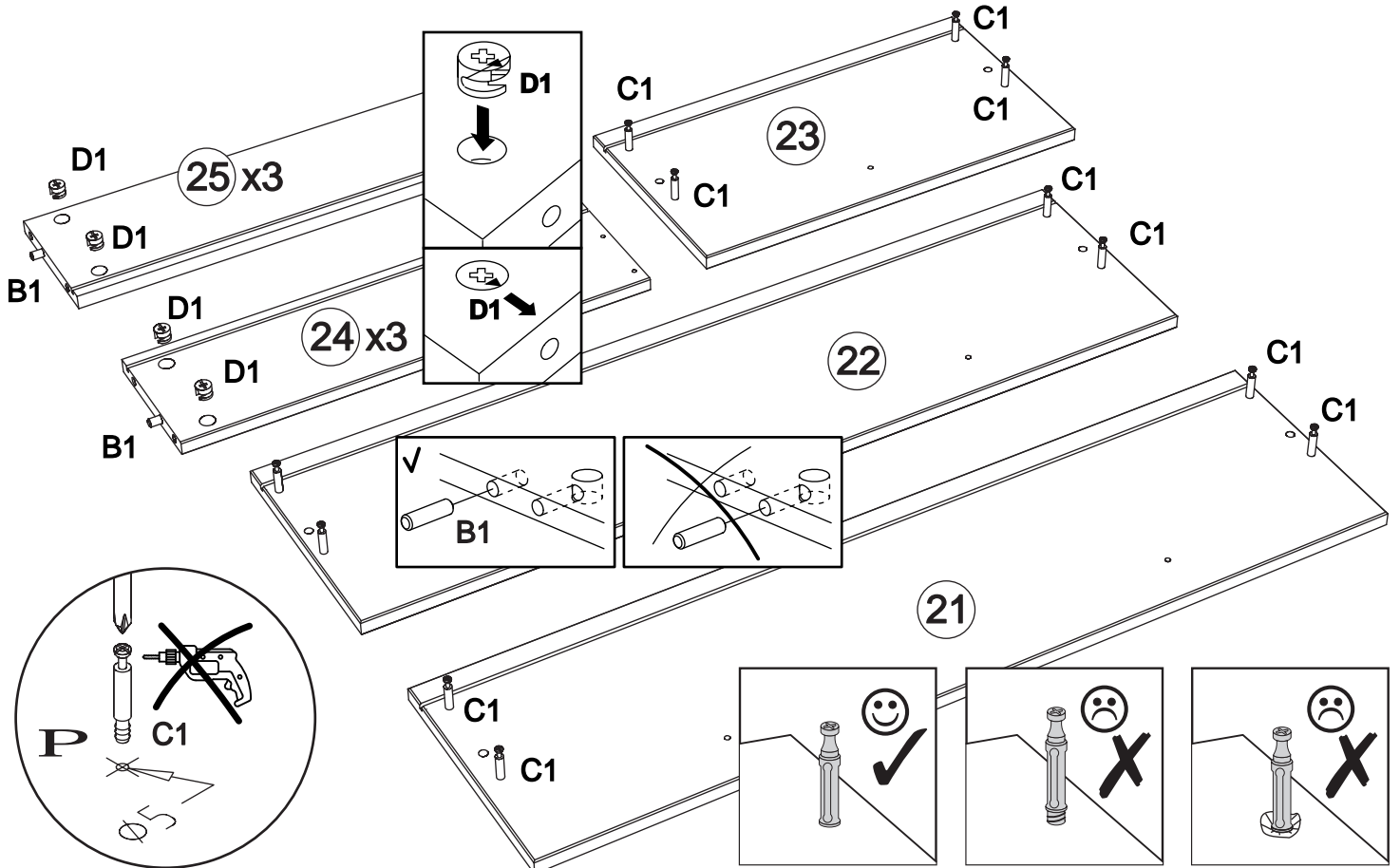
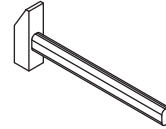
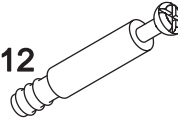

17

E5 x 12

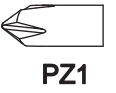
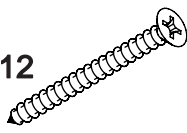

PZ1

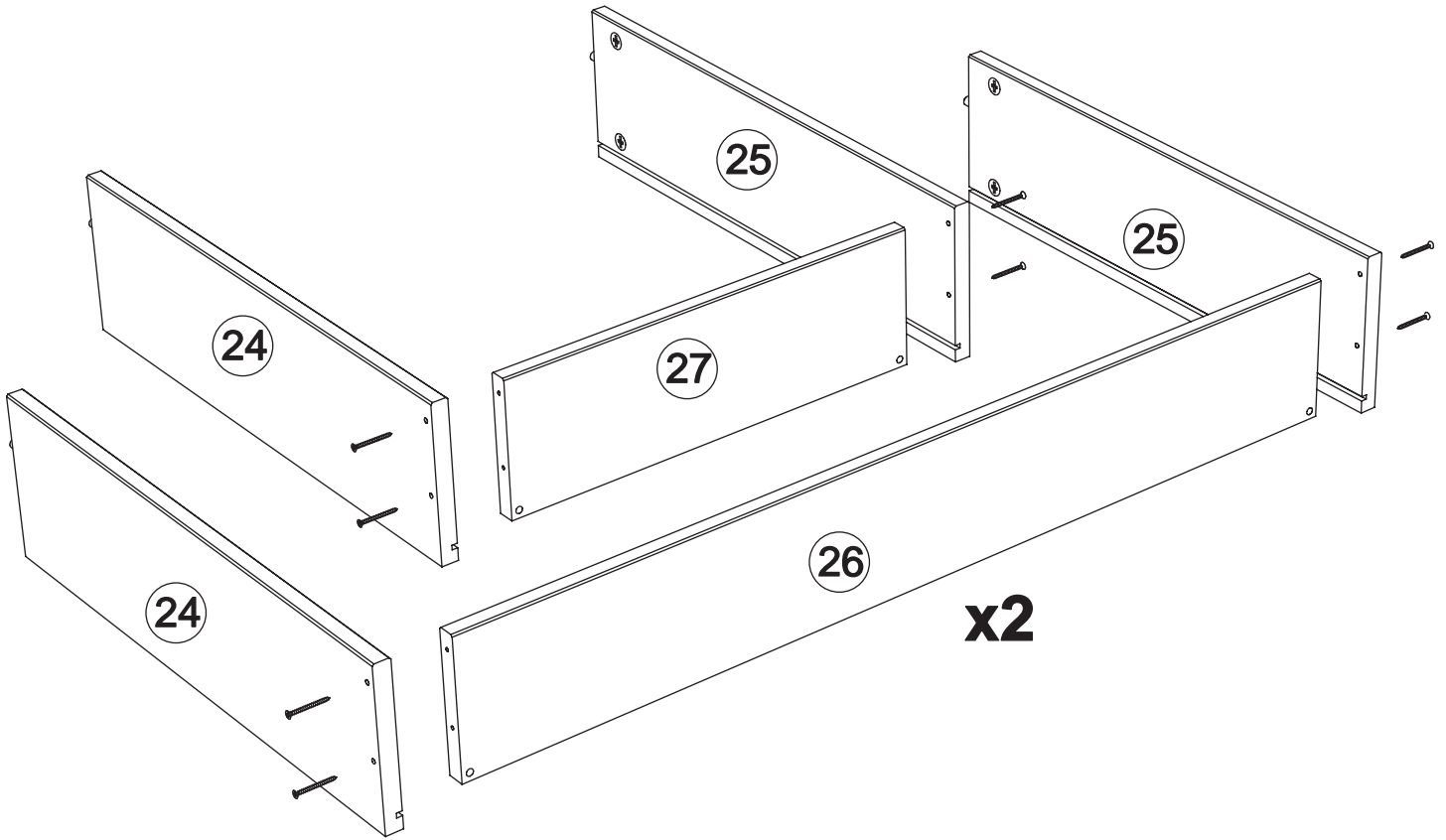

18

D3 x 12

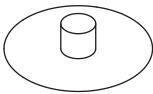

PZ2

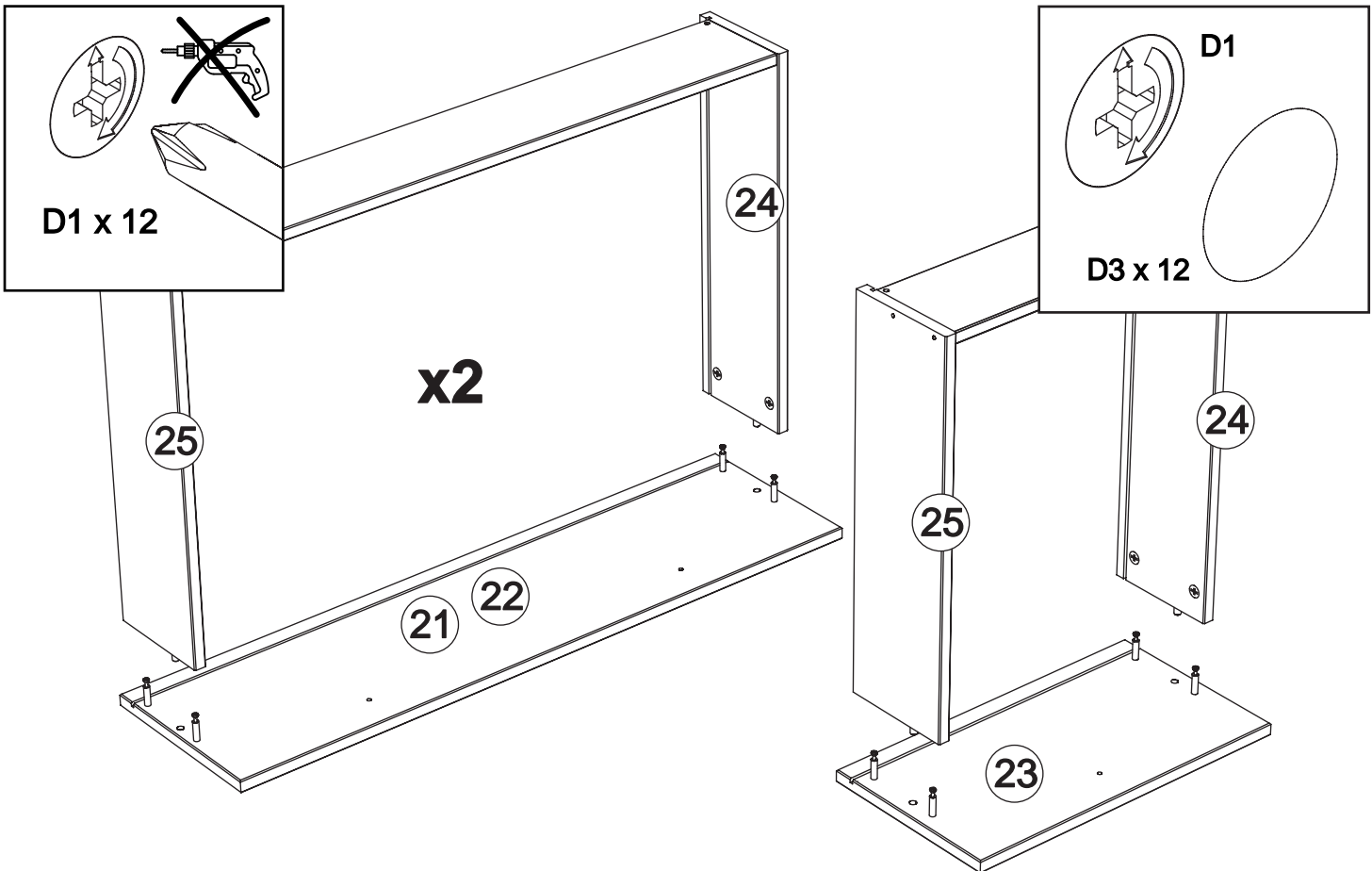

19

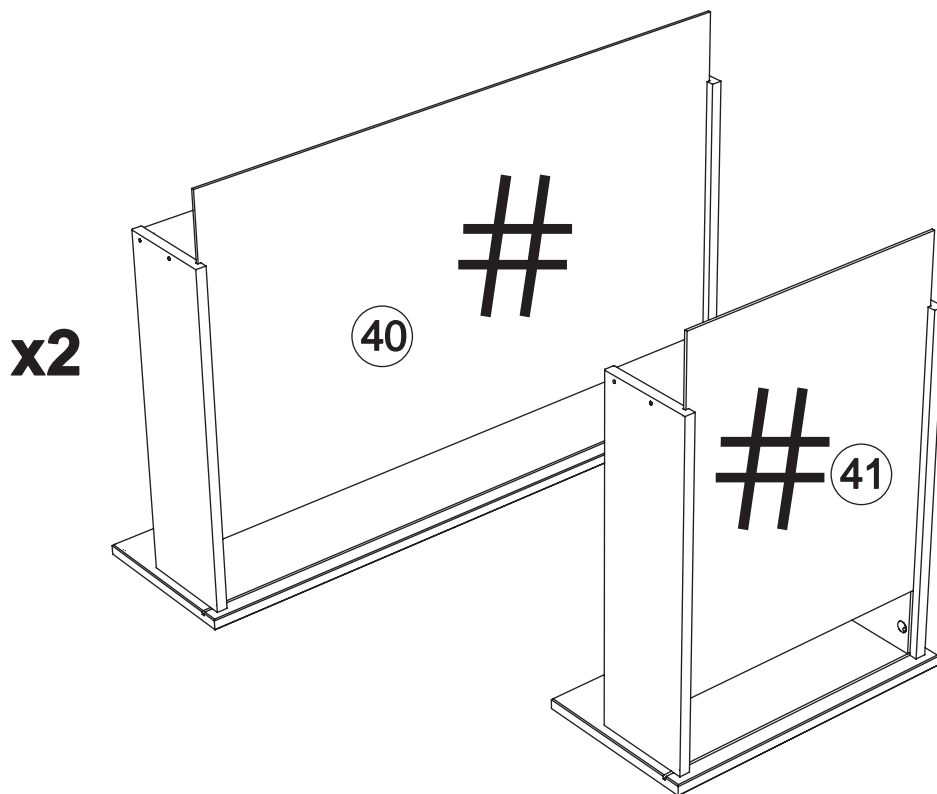

20

F11 x 11

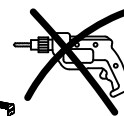
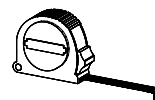
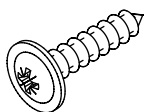

PZ1

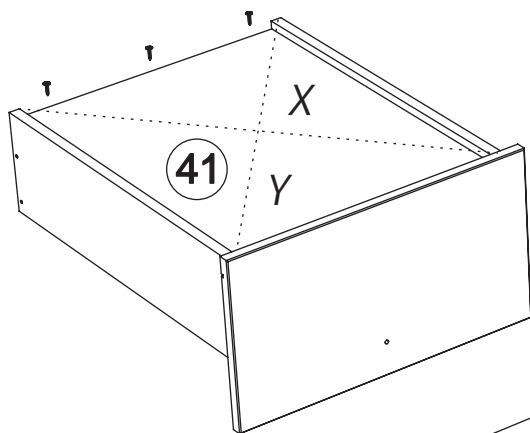

X = Y

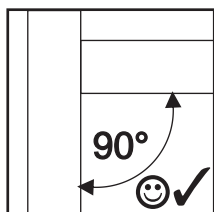
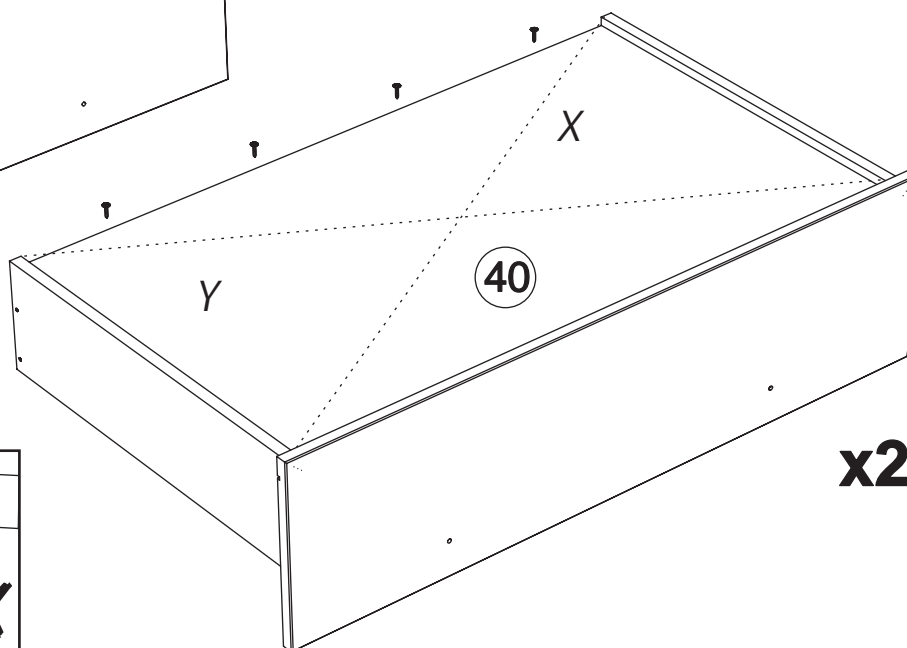

21

S17 x 3

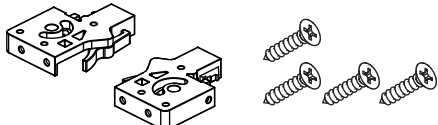

PZ2

x2

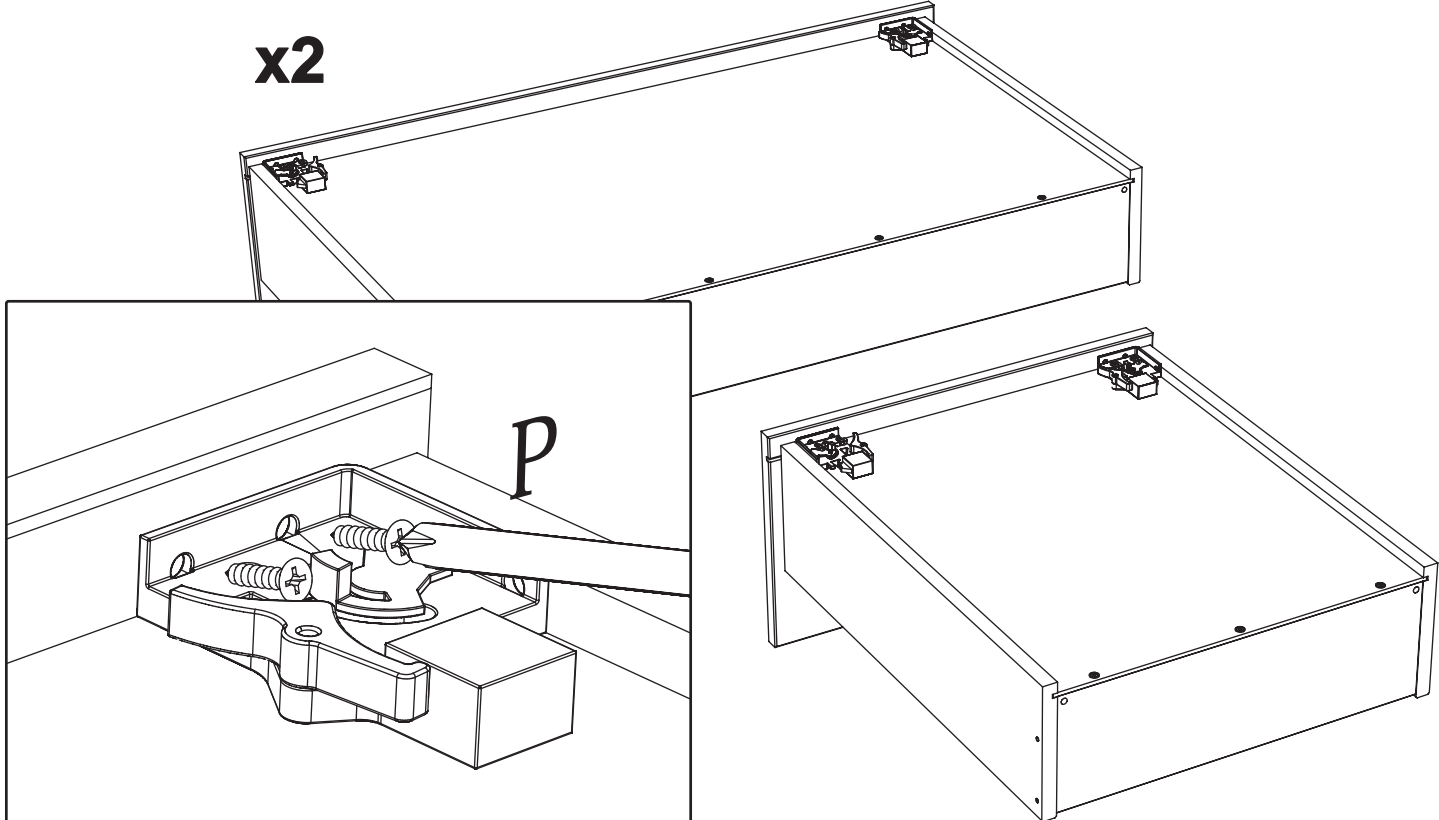

22

R7 x 5

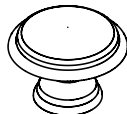

J2 x 5

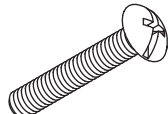

PZ2

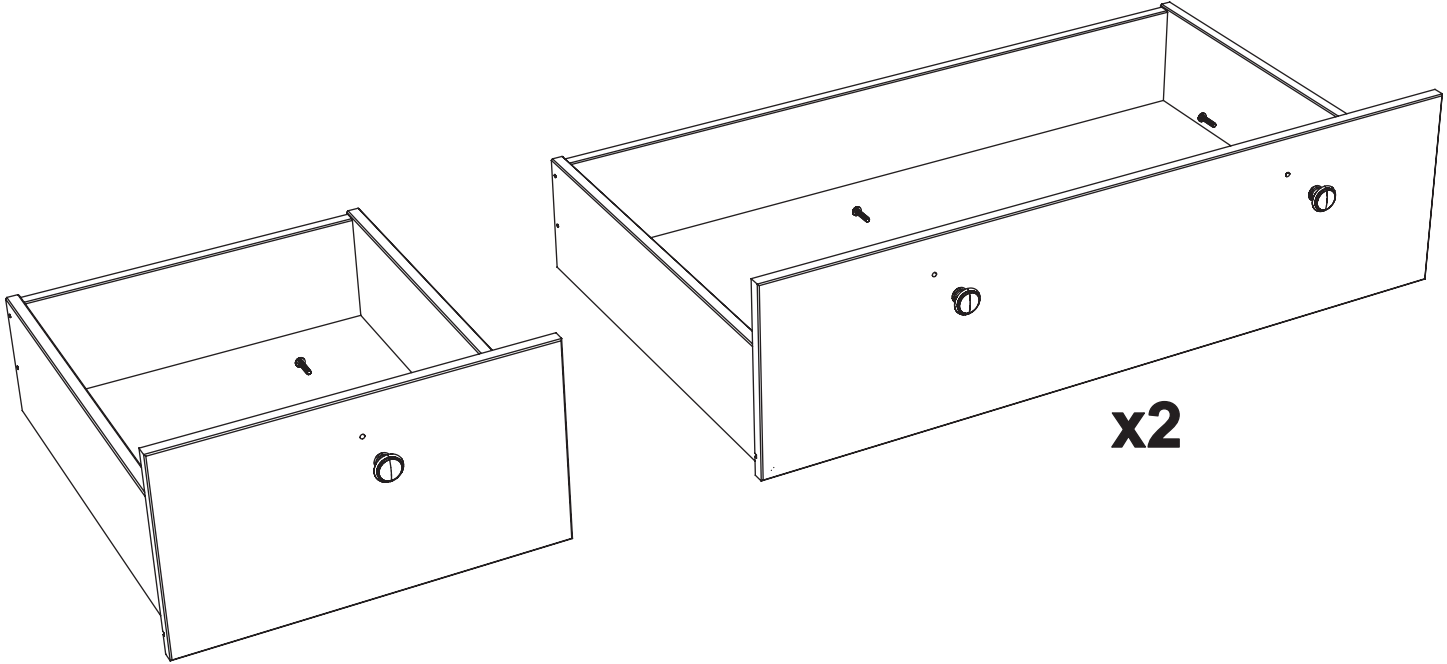

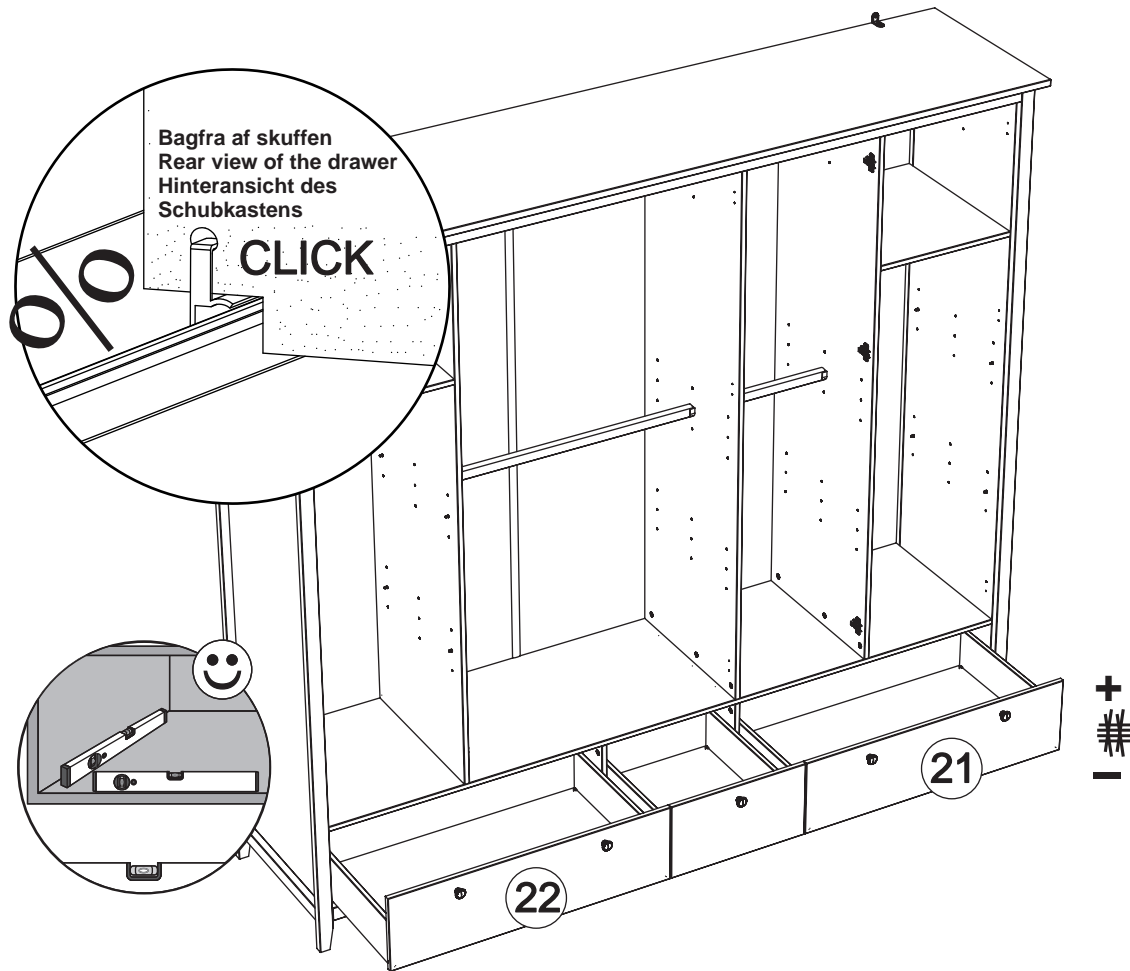

CLICK

| Achtung • Attention • Attenzione<br>Opgelet • Uwaga • Pozor • Figyelem<br>Aten ie • Dikkat |  |
|--|--|
| !  | Stellen Sie sicher, dass die Möbel eben sind. Wenn die Möbel nicht ausgerichtet sind, funktionieren die Schubladen möglicherweise nicht richtig, haften und brechen die Führungen. |
| D  | Make sure the furniture is level. If the furniture is not aligned, the drawers may not work properly, clinging, and breaking the guides.   |
| GB   | Assurez-vous que les meubles sont de niveau. Si les meubles ne sont pas alignés, les tiroirs peuvent ne pas fonctionner correctement, s'accrocher et casser les guides.            |
| FR   | Assicurarsi che i mobili siano in piano. Se i mobili non sono allineati, i cassetti potrebbero non funzionare correttamente, aderendo e rompendo le guide.                         |
| IT   | Zorg ervoor dat het meubilair waterpas staat. Als het meubilair niet is uitgelijnd, werken de lades mogelijk niet goed, kleven ze vast en breken ze de geleiders.                  |
| NL   | Upewnij si, e meble s wyzoziomowane. Je li meble nie s wyrównane, szuflady mog nie działa prawidłowo, przywieraj c i łami c prowadnice.  |
| PL   | Ujist te se, že je nábytek ve vodorovné poloze. Pokud nábytek není zarovnaný, zásuvky nemusí fungovat správn , držet se a porušovat vodítka.                                       |
| CZ   | Skontrolujte, i je nábytok vo vodorovnej polohe. Ak nábytok nie je zarovnaný, zásuvky musia správne fungova , drža sa a zlomi vodítka.   |
| SK   | Ellen rize, hogy a bútorok vízszintesek vannak-e. Ha a bútor nem igazodik, el fordulhat, hogy a fiókok nem m ködnek megfelelő en, beragadhatnak és eltörhetnek a vezető k.         |
| HU   | Asigura i-v c mobila este la nivel. Dac mobilierul nu este aliniat, sertarele pot s nu func ioneze corect, s se aga e is sparg ghidajele.  |
| RO   | Mobilyaların düz oldu undan emin olun. Mobilyalar hizalı de ilse, çekmeceler düzgün çalı mayabilir, kılavuzları yapı trabilir ve kırabilir.  |
| TR   |  |
| RU   |  |

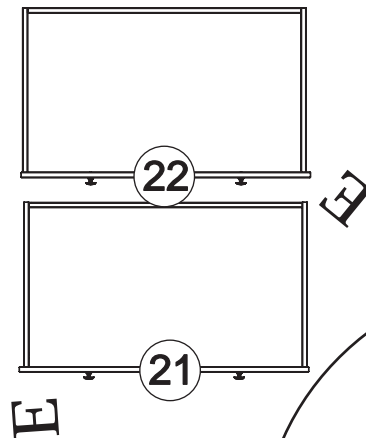

Højdejustering  
Height adjustment  
Höhenverstellung

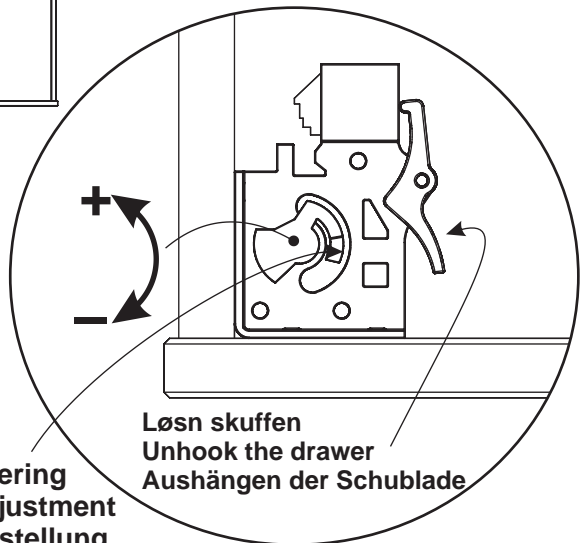

Løs skuffen  
Unhook the drawer  
Aushängen der Schublade



24

F2 x 30

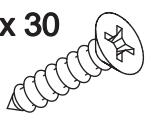

V25 x 6

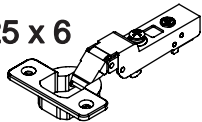

V26 x 9

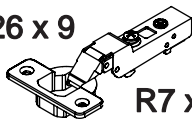

R7 x 5

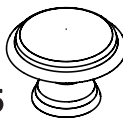

J2 x 5

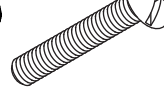

PZ2

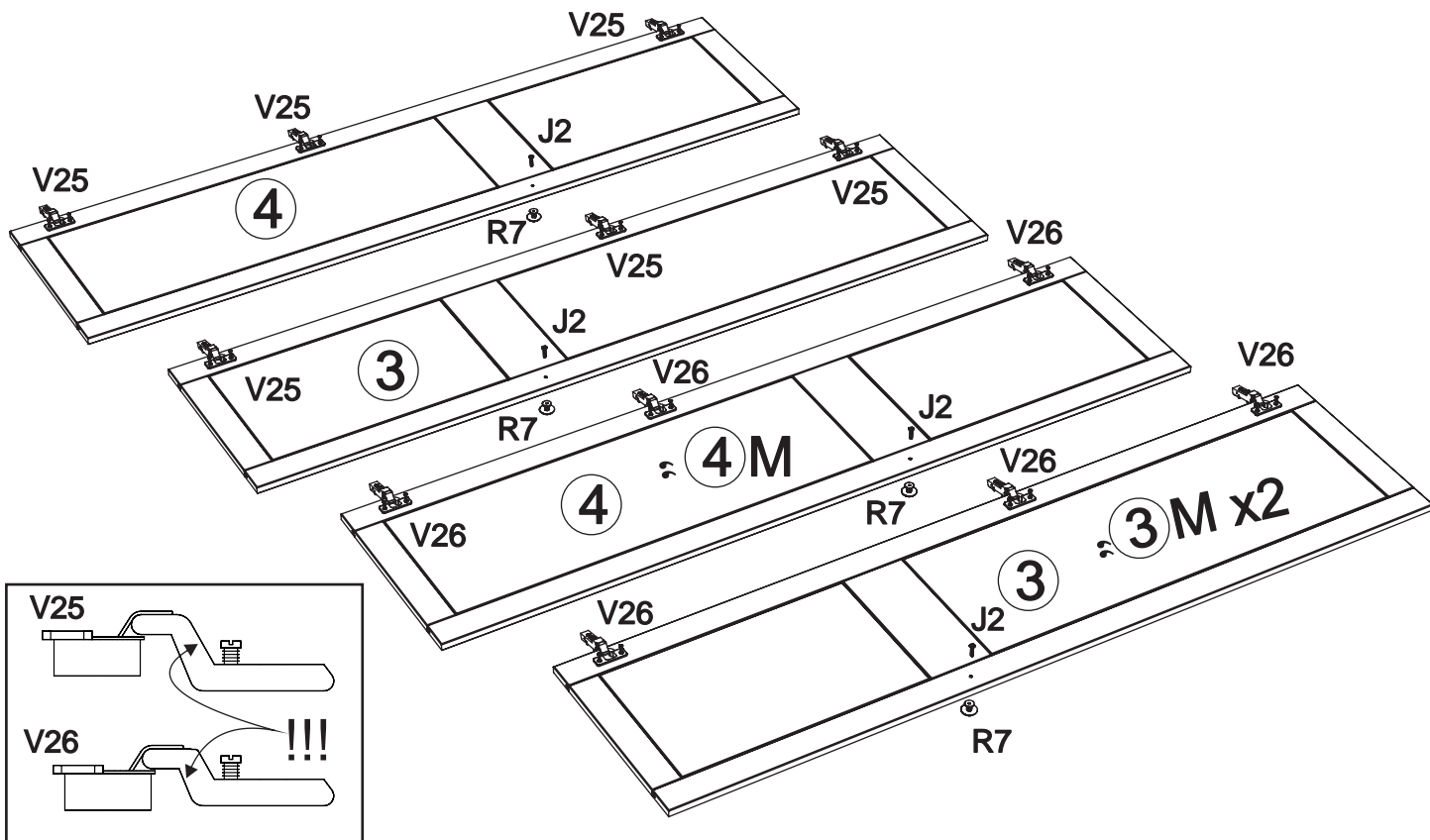

25

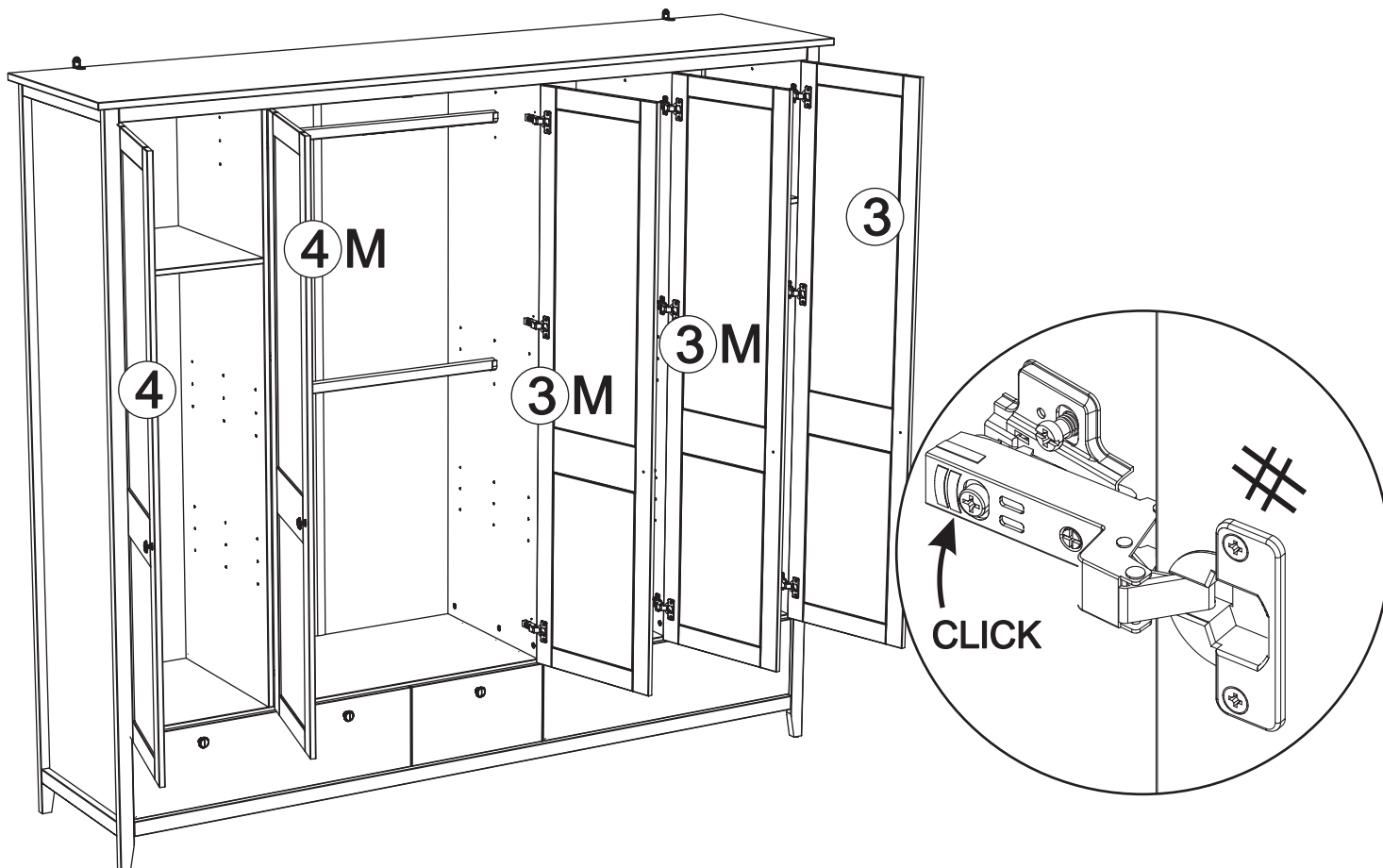

26

Q1 x 16



D3 x 24

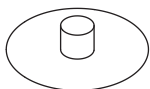

V25, V26 x 15

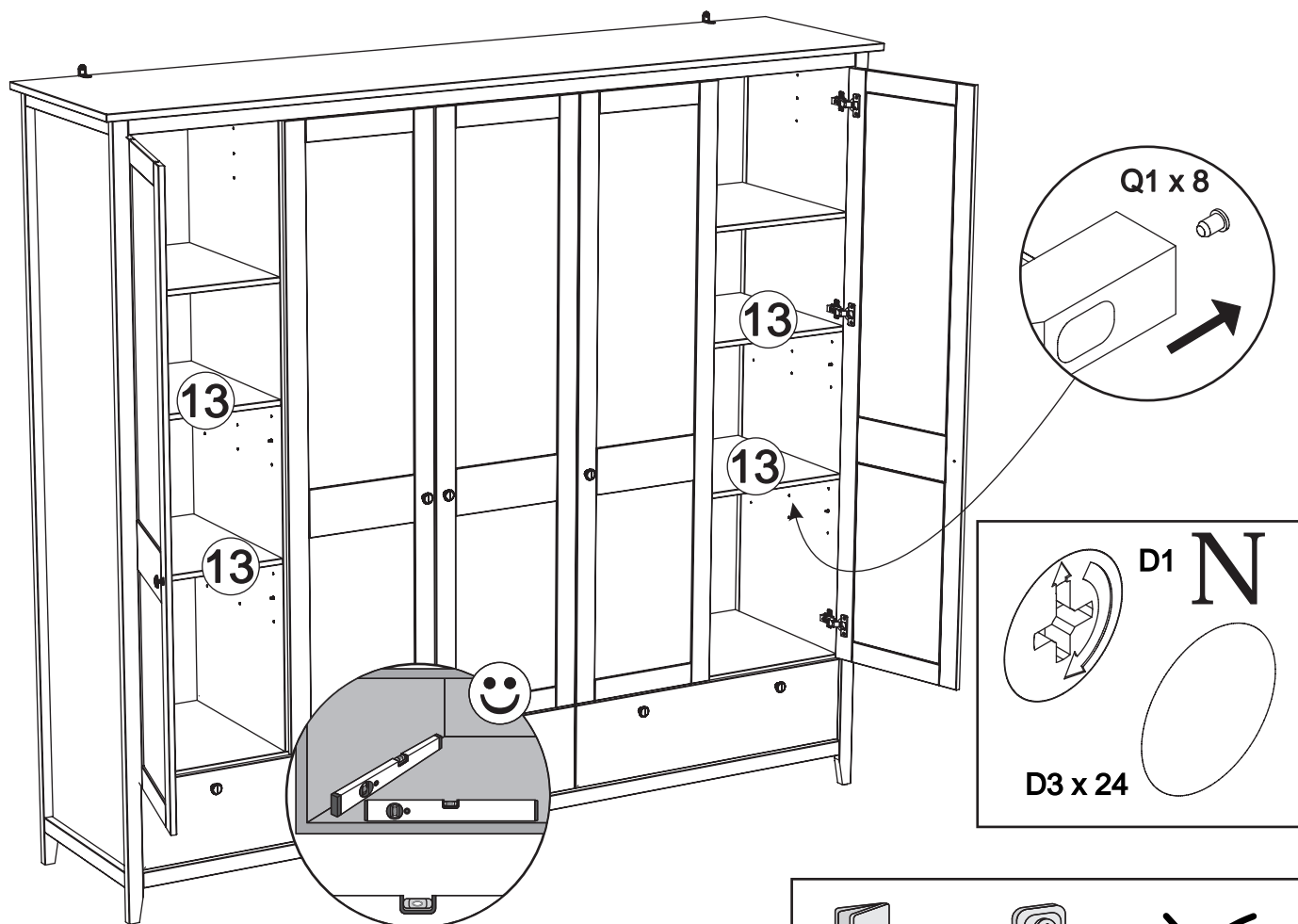
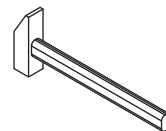
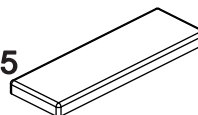

| ! Achtung • Attention • Attenzione<br>Opgelet • Uwaga • Pozor • Figyelem<br>Aten ie • Dikkat • ! |  |
|--|--|
| (D)  | Stellen Sie sicher, dass die Möbel eben sind, bevor Sie die Tür einstellen. Wenn die Möbel nicht geebnet sind, stehen die Türen und Schubladen schräg.         |
| (GB)   | Make sure the furniture is level before adjusting the door. If the furniture is not leveled, the doors and drawers will stand at an skew.                      |
| (FR)   | Assurez-vous que les meubles sont de niveau avant de régler la porte. Si les meubles ne sont pas de niveau, les portes et les tiroirs se tiendront de travers. |
| (IT)   | Assicurarsi che i mobili siano in piano prima di regolare la porta. Se i mobili non sono livellati, le ante e i cassetti saranno inclinati.                    |
| (NL)   | Zorg ervoor dat het meubilair waterpas is voordat u de deur aanpast. Als het meubilair niet waterpas staat, staan de deuren en laden scheef.                   |
| (PL)   | Przed wyregulowaniem drzwi upewnij się, że meble są wypoziomowane. Je li meble nie zostaną wypoziomowane, drzwi i szuflady staną pod kątem.                    |
| (CZ)   | Před seřízením dveří se ujistěte, že je nábytek ve vodorovné poloze. Pokud nábytek není vyrovnán, budou dveře a zásuvky stát zkoseně.                          |
| (SK)   | Préd nastavením dverí sa uistite, že je nábytok vyrovnaný. Ak nábytok nebude vyrovnaný, dvere a zásuvky budú stáť šikmo.                                       |
| (HU)   | Az ajtó beállítása előtt ellenőrizze, hogy a bútort vízszintesen van-e. Ha a bútort nincs kiegyenlítve, az ajtó és a fiókok ferdén állnak.                     |
| (RO)   | Asigurați-vă că mobilierul este la nivel înainte de a regla ușa. În cazul în care mobilierul nu este nivelat, ușa și sertarele vor sta în picioare.            |
| (TR)   | Kapıyı ayarlamadan önce mobilyaların düz olduğundan emin olun. Mobilya düz değilse, kapılar ve çekmeceler eğik olur.   |
| (RU)   |  |

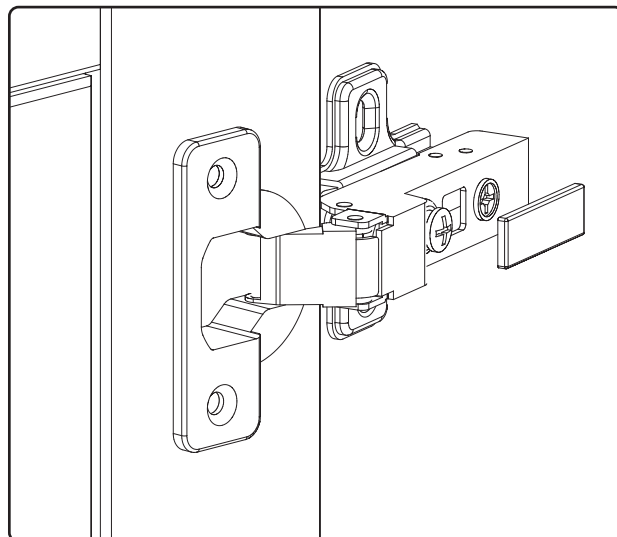
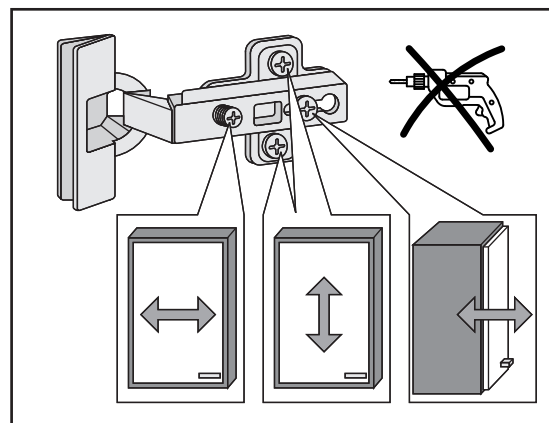

# HOLZ LEBT - SO AUCH IHR MASSIVHOLZMÖBEL

## DAS NATURPRODUKT HOLZ

Holz ist kein uniformer oder homogener Werkstoff - jeder Baum, jedes Stück Massivholz hat seine eigenen, unverwechselbaren Merkmale. Somit haben auch Möbel aus Massivholz besondere Ursprungszeichen. Charakteristisch für diesen naturgewachsenen Werkstoff sind Farb- und Strukturunterschiede, Verwachsungen, Unregelmäßigkeiten, Druckstellen, Äste, Harzgallen, Haar- und Kreuzrisse auch im Lack sowie Spannungen (Drehwuchs), die je nach Holzart und Wuchsgebiet unterschiedlich sind. Es sind Echtheitsmerkmale, die dem Holz erst die natürliche Schönheit verleihen und jedes Stück Möbel zu einem Unikat werden lassen.

Auf schwankende Raumtemperaturen und Luftfeuchtigkeit - auch jahreszeitbedingt - reagiert Holz, es „arbeitet“. Spannungen im Holz sowie ein Verziehen des Holzes sind daher nicht immer auszuschließen. Um die Stabilität zu verbessern, werden sogenannte Leimholzplatten als Basis für Massivholzmöbel genutzt. In einem aufwendigen Produktionsverfahren werden einzelnen Lamellen mit schadstofffreiem Leim an Kopf und/oder Seite zusammengesetzt. Diese Lamellen können in Breite und Länge innerhalb einer Platte unterschiedlich sein. Es ist handelsüblich, holzbedingte Fehler durch Einsetzen von Astspots und/oder Lamellos zu beseitigen.

Alle vorgenannten Merkmale sind ein Beweis des natürlichen Ursprungs und geben keinen Anlass zu Beanstandungen. Funktion, Gebrauch, Wert und Haltbarkeit dieser Möbel werden dadurch nicht beeinträchtigt.

## EIGENSCHAFTEN VON HOLZ



Äste



Spannungen



Farbunterschiede



Quelle



Schwinden

FOLGENDES RAUMKLIMA IST OPTIMAL  
FÜR SIE UND IHR MASSIVHOLZMÖBEL:

Stabile Temperatur 18-23°C  
Stabile Luftfeuchtigkeit von 45-55%  
Kein direktes Sonnenlicht auf das Möbel

## BESONDERHEITEN

Die Lebensgeschichte eines Baumes wird durch charakteristische Merkmale wie Zeichnung, Struktur und Farbe geprägt. Kein Baum gleicht dem anderen. Diese abweichenden Natur- und Wachstumsmerkmale machen aus jedem individuellen planbaren Echtholzmöbel in modellbezogener Material- und Verarbeitungsstruktur ein echtes Unikat mit einem einzigartigen Erscheinungsbild. Eine absolute Farb- und Strukturgleichheit, beispielsweise zwischen Planungsmuster und Lieferung, kann deshalb nicht garantiert werden. Diese Natur-Farbspiele sind eine warentypische Eigenschaft des gewachsenen Naturwerkstoffes und ein wesentliches, unverwechselbares Echtheitsmerkmal, kein Beanstandungsgrund.

## LUFTFEUCHTIGKEIT

Holz ist ein natürlicher Werkstoff, der ständig Feuchtigkeit aufnimmt und wieder abgibt, je nach dem Feuchtigkeitsgehalt der lokalen Umgebung. Darum sollten Möbel keiner extrem großer oder zu niedriger Luftfeuchtigkeit ausgesetzt werden. Das Holz beginnt sonst wieder zu arbeiten, sich zu verziehen, offene Leimfugen oder Risse zu zeigen. Das Raumklima, das für Mensch und Pflanzen am besten ist (Medizin und Wissenschaft empfehlen Jahresdurchschnittswerte von 45-55% Luftfeuchtigkeit bei 18-23°C, kurzfristige Abweichungen von diesen Empfehlungen schaden nicht), ist auch für Kastenmöbel richtig.

## LICHTEINWIRKUNG BEI MÖBELN

Starkes Kunst- und insbesondere Sonnenlicht verändern Oberflächen, besonders Holzoberflächen. Diese Art von „Sonnenbrand“ lässt Naturhölzer vergilben, gebeizte Hölzer ausbleichen. Schützen Sie Ihre wertvollen Möbel unbedingt vor extremer Lichteinwirkung, da eine 100-prozentige Lichtechtheit materialbedingt nicht zu erreichen ist. Das Sonnenlicht verändert alle Materialien! Besondere Vorsicht ist deshalb in hellen Südzimmern mit viel Glas geboten, dort sollten bei direkter Sonneneinstrahlung Vorhänge oder Jalousien geschlossen werden, da sonst eine Oberfläche schon nach wenigen Wochen an den beschienenen Stellen holzartbezogen heller oder dunkler werden kann.

## FAZIT

Massives Holz ist ein „lebendiger“ Werkstoff, der sich bei starken Schwankungen von Temperatur und Luftfeuchtigkeit geringfügig ändern kann. Da für diese Möbel nur gut abgelagerte Hölzer verwendet werden, ist dieser Effekt auf ein Minimum begrenzt. Funktion und Gebrauchswert sind keinesfalls eingeschränkt. Extrem trockener Zentralheizungs- und überhöhter, sowie extrem nassen und niedrigen Zimmertemperaturen sollten Massivholzmöbel nicht ausgesetzt werden.